

Agilent Technologies E6559A Lucent AMPS/TDMA Base Station Test Software

User's Guide

Software Version: B.03.00 and later

Agilent Part Number E6559-90001

Revision C

Printed in UK.

May 2000



Agilent Technologies

Restricted Rights Legend

Use, duplication or disclosure by the U. S. Government is subject to restrictions as set forth in subparagraph (c) (1) (ii) of the Rights in Technical Data and Computer Software clause in DFARS 252.227-7013.

Agilent Technologies
3000 Hanover Street,
Palo Alto, CA 94304. U.S.A.

Rights for non-DOD U. S. Government Departments and Agencies are as set forth in FAR 52.227-19 (c) (1, 2).

Information contained in this document is subject to change without notice.

All Rights Reserved. Reproduction, adaptation, or translation without prior written permission is prohibited, except as allowed under the copyright laws.

This material may be reproduced by or for the U.S. Government pursuant to the Copyright License under the clause at DFARS 52.227-7013 (APR 1988).

© Copyright 1999, 2000 Agilent Technologies

Trademark Acknowledgements

Hewlett-Packard and HP are registered trademarks of Hewlett-Packard Company.

Microsoft, Windows, and MS-DOS are registered trademarks of Microsoft Corporation.

Pentium is a registered trademark of Intel Corporation.

In this Manual	8
Conventions Used	9
Product Description	
Overview	12
Who should use the Test Software?	13
Included with the Test Software	13
Test Software Operation Overview	14
Required Equipment	15
Test Equipment	15
Personal Computer (PC)	15
Cables and Adapters	15
Optional Accessory Kits	17
Getting Help, Test Software Upgrades, and Training	20
Installation	
Overview	22
Loading and Running the Test Software	23
Navigating the Test Software	25
Main Menu Functions	25
Changing Settings and Using USER Keys	26
Operating the BTS Laptop Utility Program	27
System Requirements for BTS Laptop Utility Program	28
Installing the BTS Laptop Utility Program	28
Configuring the Test Set and PC Serial Ports for Communication with the	
Test Set	29
Configuring the PC to Communicate with the MSC	31
Connecting the PC to the Test Set and the MSC	32
Connecting the PC to the Test Set	32
Connecting the PC to the MSC	33
Determining the Test Set to Site Equipment Connections	36
Which Test Set Port to Use – ANT IN or RF IN/OUT?	36
Which Base Station Port to Use – TX Test or TX Antenna?	36
Configuring the Test Software	38
Test Configuration	39
Base Station Configuration	41
Printing the FCC Title Page	43
Defining a Frequency Plan	45
Defining a Frequency Plan Using the Editor in the Test Software	45
Defining a Frequency Plan Using a PC	48
Loading a Frequency Plan from an SRAM Card	52
Purging (Deleting) a Frequency Plan File	52
Printing a Frequency Plan	53
Establishing a Connection with the MSC for Testing	54

Contents

Establishing a Direct-Dial Modem Connection	54
Establishing a Telnet Connection	54
If You Noticed Problems	55
Connections	
Test Set to Base Station Connections	58
Performing Tests	
Overview	62
Calibrating the Test Setup	63
Selecting Tests	64
Selecting Utilities	65
Running Tests	66
For More Information	66
Full Site Test (FCC)	67
Measurements	67
Parameters and Specifications Used	68
Select and Run the Test	69
Review the Results	69
Single Radio Test	70
Measurements	70
Parameters and Specifications Used	71
Select and Run the Test	72
Review the Results	72
TX Power Adjustment	74
Parameters and Specifications Used	74
Select and Run the Test	74
Review the Results	75
Spectrum Analyzer	77
Parameters and Specifications Used	77
Select and Run the Test	77
Review the Results	78
TX Gain Test	80
Parameters and Specifications Used	80
Select and Run the Test	80
Review the Results	81
RX Gain Test	82
Parameters and Specifications Used	82
Select and Run the Test	82
Review the Results	83
TX -39 dBm Power Test	84
Parameters and Specifications Used	85
Select and Run the Test	85
Review the Results	86

TX Antenna Port Cable Calibration	87
Parameters and Specifications Used	87
Select and Run the Utility	87
Review the Results	88
TX Test Port Cable Calibration	89
Parameters and Specifications Used	89
Select and Run the Utility	89
Review the Results	90
TX Test Port Coupling Measurements	91
Parameters and Specifications Used	91
Select and Run the Test	92
Review the Results	93
Insertion Loss Measurement	94
Parameters and Specifications Used	94
Select and Run the Test	94
Review the Results	95
Return Loss Measurement	96
Parameters and Specifications Used	96
Select and Run the Test	96
Review the Results	97
Reference	
Overview	100
Accessing Test Software Functions	101
SOFTWARE MENU Screen Overview	102
Loading a Test Procedure	103
Loading the Test Software Card and Procedure	104
Customizing a Test Procedure	106
Changing Test Parameters	107
Changing Pass/Fail Limits	110
Saving/Deleting a Procedure	113
BTS Laptop Utility Program Windows	117
Switch Terminal Window	117
Test Set Terminal Window	117
Other Data Window	117
Test Results Window	118
Test Set Screen Capture Window	119
Demo (Demonstration) Mode	120
Selecting the DEMO Procedure	120
Selecting Demo Mode Using the Control Parameter	120
Exiting the Demo Mode	121
Parameters	122
Specifications (Pass/Fail Limits)	129

Testing without MSC Control	132
Using a PC Card	133
Initializing a PC Card	133
Troubleshooting PC Card Use	133
Troubleshooting	
Error Summary	136
Overview	136
Troubleshooting the Test Software Installation	137
Errors When Loading and Running the Test Software	138
Communication Errors	139
Errors When First Setting Up or Connecting to MSC	139
Communication Errors During Testing	139
Troubleshooting Checks for Communication Problems	140
Errors While Attempting Measurements	141
Troubleshooting Frequency Plans	142
Acronyms 143	
Acronyms and Meanings	144

Preface

In this Manual

This manual consists of the following parts:

[Chapter 1, “Product Description,” on page 11.](#)

This chapter provides a general description of the Agilent Technologies E6559A Lucent AMPS/TDMA Base Station Test Software.

[Chapter 2, “Installation,” on page 21.](#)

This chapter provides information on loading and running the Test Software, connecting the equipment, and configuring the Test Set and Test Software.

[Chapter 3, “Connections,” on page 57.](#)

This chapter provides information on connecting the Test Set to the Base Station and other equipment.

[Chapter 4, “Performing Tests,” on page 61.](#)

This chapter provides procedures for running the Test Software tests and utilities, and descriptions of the individual tests and utilities.

[Chapter 5, “Reference,” on page 99.](#)

This chapter provides operational details that are not covered elsewhere in this manual. Topics are arranged alphabetically for quick and easy reference.

[Chapter 6, “Troubleshooting,” on page 135.](#)

This chapter provides information on possible remedies in the event of operational problems.

[Appendix A, “Acronyms,” on page 143.](#)

This appendix provides a list of acronyms and the associated meanings to assist in efficient Test Software operation.

Conventions Used

Special presentations of text in this manual reflect the appearance of the referenced item. Examples of these special presentations are:

Menu – A Test Set front panel key.

Pause/Continue (Reset) – A Test Set front panel *shift* function key. The key name in parentheses is the title of the shift function. Press the **Shift** key then the specified key to access the *shift* function.

Procedure: – Characters that appear on the Test Set display.

k1 (Run Test) – A USER key in the key column next to the display. The words in parentheses are displayed on the screen.

Title – Titles of documentation are printed in italics.

Test Set – Refers to the Agilent Technologies 8935 Series E6380A CDMA Base Station Test Set.

Test Software – Refers to the Agilent Technologies E6385A Lucent CDMA Base Station Test Software.

TEST – Refers to the one of the test modules that is part of a test procedure.

PC card – Refers to either the OTP card on which the Test Software is shipped or the SRAM card that is shipped with the Test Software for storing procedures.

PC card is an industry standard term that refers to two types of information storage cards. One meets the specifications of the Personal Computer Memory Card International Association (PCMCIA). The other meets the specifications of the Epson Corporation PC card standard. Agilent Technologies 8935 Series Test Sets use only the PCMCIA type card.

OTP card – Refers to the type of PC card that is used to store the Test Software.

SRAM card – Refers to the type of PC card that is shipped with the Test Software for storing procedures.

BTS – Refers to a Base Transceiver Station.

In procedural steps in this manual, the following words are used to describe cursor and entry actions:

- **Select** – refers any of three possible actions:
 - Positioning the cursor at the appropriate field (**inverse video** area) and pressing the knob.
 - Making an entry using the DATA ENTRY keys and pressing the knob.
 - Making an entry using the DATA ENTRY keys and pressing the **Enter** key.
- **Enter** – means to use the numeric keypad, and the **Enter** key or measurement units keys to make entries to fields. In some procedures, the word “enter” is used to describe the action of entering characters into a field.

1 Product Description

This chapter provides general information about the Agilent Technologies E6559A Lucent AMPS/TDMA Base Station Test Software. Included is a list of required equipment to perform the tests, plus a look at the basic Test Software flow.

Overview

The Test Software is contained on a One-Time Programmable (OTP) PC card.

The Test Software is an Agilent Technologies Instrument BASIC (IBASIC) application used to set up the Test Set for transmitter measurements on AMPS and TDMA Base Station equipment. The Test Software runs on the Test Set internal IBASIC controller to allow you to perform the following tests:

- Full Site Test (FCC)
- Single Radio Test
- TX Power Adjustment Test
- Spectrum Analyzer Test
- RX Gain Test
- TX Gain Test
- TX -39 dBm Power Tests

Using a PC modem or a telnet connection, the Test Software can control the Base Station equipment by sending commands to the Mobile Switching Center (MSC). This provides automated testing to reduce time spent at the site and to greatly improve the repeatability of measurements.

As tests are run, the Test Software compares the measured results with user-defined specification limits. These test results may be stored on a personal computer (PC) (ordinarily a laptop PC).

In addition, the following tests are included as calibration and utilities functions.

- TX Antenna Port Cable Calibration
- TX Test Port Cable Calibration
- TX Test Port Coupling Measurements
- Insertion Loss Measurement
- Return Loss Measurement

Also in addition, the following two miscellaneous utilities are included:

- Define Frequency Plan
- Print FCC Title Page

Who should use the Test Software?

If you are installing, commissioning, or maintaining Lucent Technologies' AMPS/TDMA cell site equipment, this Test Software will assist you in performing key tests of transmitter performance.

Included with the Test Software

The following items are included with the Test Software:

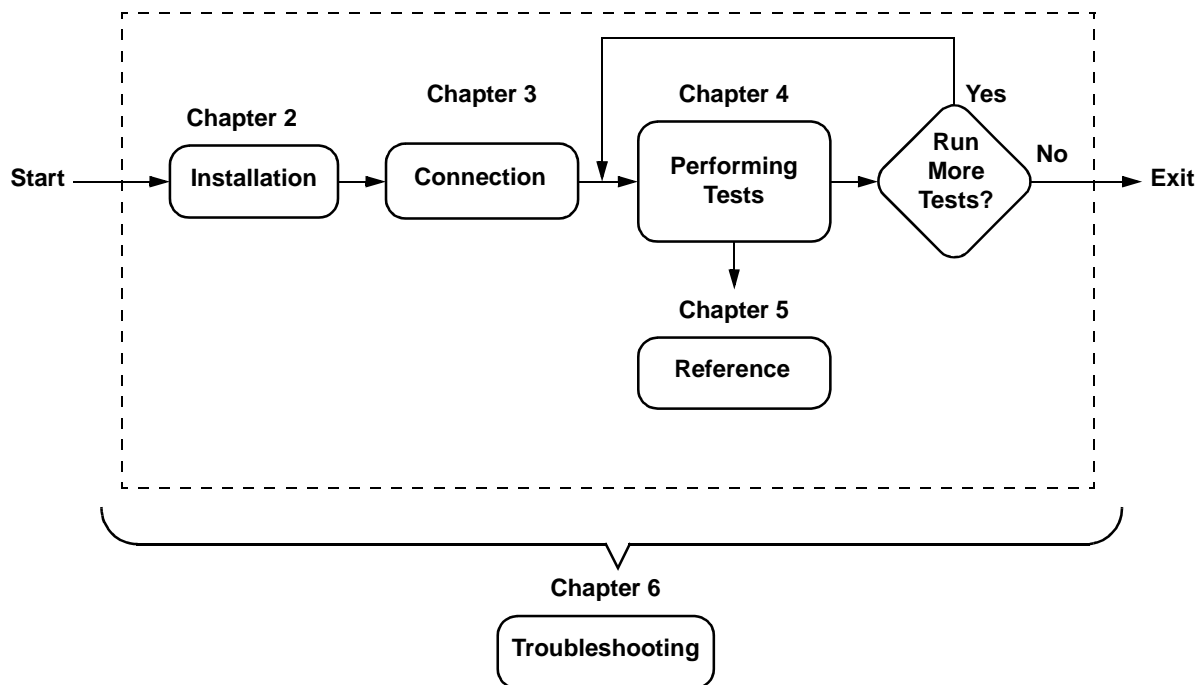
- ❑ PC Card (OTP) containing the Agilent Technologies E6559A Lucent AMPS/TDMA Base Station Test Software
Agilent Technologies Part Number: E6559-10001
- ❑ Blank 1-megabyte SRAM PC Card
Agilent Technologies Part Number: 83231A
- ❑ Two 3.5-inch diskettes containing the BTS Laptop Utility program
Agilent Technologies Part Number: E6385A Option K01
- ❑ One 3.5-inch diskette containing a Sample Frequency Plan
Agilent Technologies Part Number: 5010-1203
- ❑ Agilent Technologies E6559A Lucent AMPS/TDMA Base Station Test Software User's Guide (this manual)
Agilent Technologies Part Number: E6559-90001
- ❑ Software License Agreement

Test Software Operation Overview

Figure 1-1 illustrates the basic steps for Test Software operation. After running the Test Software, you may repeat a test or you may select another test.

Chapter 4, “Performing Tests,” on page 61, provides step-by-step instructions for each of the tests. If you have questions, refer to Chapter 5, “Reference,” on page 99 for more information. If you encounter errors, refer to Chapter 6, “Troubleshooting,” on page 135.

Figure 1-1 Using the Test Software



Required Equipment

Test equipment and other items required for testing are shown in [Figure 1-2](#) and described in the following paragraphs.

Test Equipment

The Test Software is written specifically to work with the Agilent Technologies 8935 Series E6381A TDMA Base Station Test Set.

Personal Computer (PC)

The Test Set and Test Software support using a PC to control the site via the MSC. This allows you to dial up or use a telnet connection to log in to the MSC and enter the maintenance craft shell as you would ordinarily for other cell site operations. The PC is connected to the Test Set via the SERIAL 9 port. Most PCs with an available serial port are compatible with the Test Set.

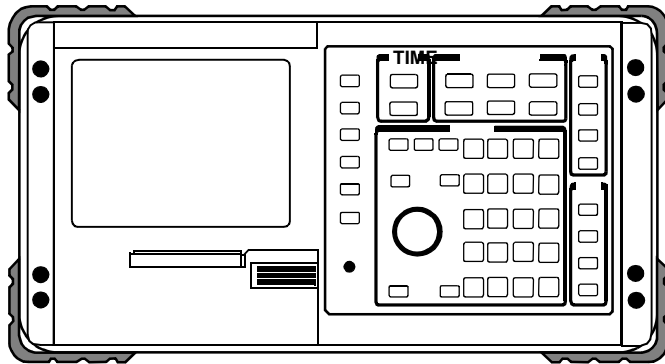
You must install the BTS Laptop Utility program in the PC, so as to relay commands to the MSC from Test Set, collect test data, log commands sent between the Test Set and the MSC, and capture screen images.

Cables and Adapters

Various cables and adapters are required. These may be purchased from Agilent Technologies or from local sources. See [“Optional Accessory Kits” on page 17](#) for information on optional accessory kits that supply the necessary cables and adapters to connect the Test Set to the Base Station equipment.

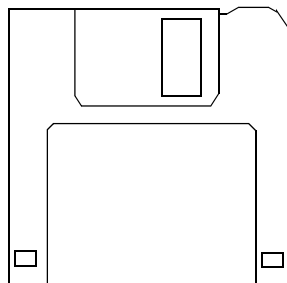
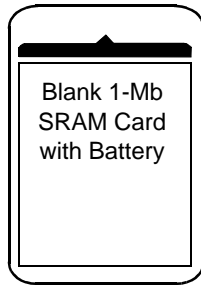
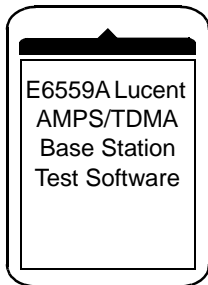
Figure 1-2 Required Equipment

Test Equipment Required:

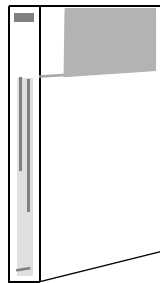


Agilent Technologies 8935 Series E6381A
 TDMA Base Station Test Set

Supplied with the Test Software:



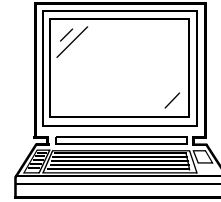
BTS Laptop Utility Program
 (E6385A Option K01)
 (Two diskettes.)



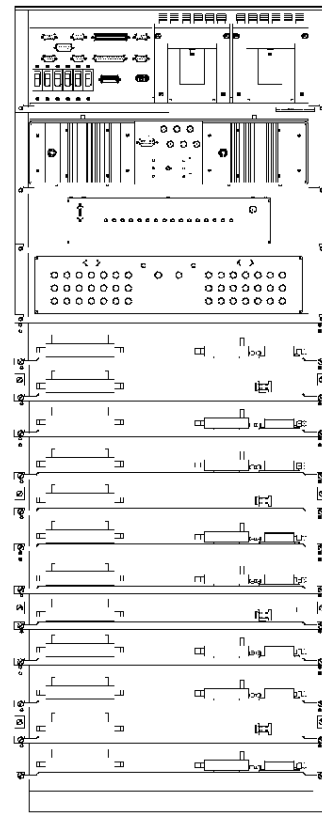
Test Software Manual
 (E6559-90001)

Sample Frequency Plan
 (5010-1203)
 (One diskette.)

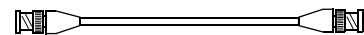
You Must Supply:



- Laptop PC with Internal Modem
- Null Modem Cable to Test Set 5182-4794



- Lucent Series II Base Station.



- Cables to Connect the Base Station to the Test System.

Optional Accessory Kits

Several kits containing selections of accessories for connecting the Test Set to the Base Station equipment are available from Agilent Technologies. These are described in the following three sections.

Agilent Technologies E8300A 8935 Base Station Accessory Kit

The Agilent Technologies E8300A 8935 Base Station Accessory Kit (see [Table 1-1](#)) supplies serial cables, RF cables, and adapters required to connect the Test Set for testing Base Stations.

Table 1-1 E8300A Base Station Accessory Kit Contents

Part	Part Number	Quantity	Use
Cable Assembly, N(M) to N(M), 10-ft.	08921-61010	1	Connects the Base Station TX Antenna Port to the Test Set RF IN/OUT port.
Cable Assembly, SMA(M) to BNC(M), 10-ft.	08921-61021	2	Connects Base Station Even Second clock and 19.6608-MHz clock to Test Set.
Cable Assembly, SMA(M) to N(M), 12-ft.	E8300-61002	1	Connects the Base Station TX Test Port to the Test Set ANT IN port.
Cable Assembly, N(M) to N(M), 2-ft.	E8300-61005	1	Used as the calibration cable for Insertion Loss test.
Null Modem Cable Assembly, DB9(F) to DB9(F), 10-ft.	5182-4794	1	Connects the PC serial port to the Test Set SERIAL 9 port.
Attenuator, N(M) to N(F), 6-dB	0955-0819	2	Used for cable loss calibration routines.
Adapter, SMA(F) TO N(M)	1250-1250	2	Used for Base Station TX Test Port Cable calibration, adapts to a Type N attenuator.
Adapter, N(F) to N(F)	1250-0777	1	Used for joining Type N cables
Adapter, TNC(M) to N(F)	1250-2361	1	Used for TNC connections on some Base Stations.
Velcro Cable Wrap	1400-2157	10	Used for securing and organizing cables for transporting and during testing.
Verification Guide	E8300-90001	1	Used as a checklist for connector kit contents.
Transit Case	E8300-61006	1	Organizes and transports connectors and cables. Includes spaces for Option 001 parts.
Strain Relief Assembly	E8300-61004	2	Reduces strain on connectors from cables.
Strain Relief Application Guide	E8300-90005	1	Instructions for using strain relief assemblies.

Agilent Technologies E8300A Option 001 Accessory Kit

The E8300A Option 001 Accessory Kit (see [Table 1-2](#)) includes the additional parts that are required to run all of the Test Set built-in RF Tools routines. The RF Tools routines are automated measurements used in cell site maintenance (such as antenna sweeps).

Table 1-2 E8300A Option 001 Accessory Kit Contents

Part	Part Number	Quantity	Use
Cable Assembly, N(M) to N(M), 2-ft.	8120-8687	2	Used to connect the Test Set to the VSWR bridge.
VSWR Bridge	0955-0829	1	Used to measure return loss
Termination, 50-ohm, N(M)	1250-2656	1	Used to terminate transmission lines.
Termination, short, N(M)	1250-2655	1	Used to terminate the DUT port of the VSWR bridge during return loss tests.
Resistive Power Splitter, 2-way	0955-0827	1	Divide a signal in two.

Agilent Technologies E6554A 8935 RF Tools Hardware Accessory Kit

NOTE

If you do not purchase the Agilent Technologies E8300A Accessory Kit, you may order the Agilent Technologies E6554A RF Tools Hardware Accessory Kit to provide all of the required connectors, cables, and accessories to run the RF Tools tests.

The Agilent Technologies E6554A 8935 RF Tools Hardware Accessory Kit (see [Table 1-3](#)) contains the equipment necessary to run the “Return Loss Measurement” on page 96 and to run the RF Tools ROM programs that reside in the Test Set. Refer to the *Agilent Technologies 8935 TDMA Cellular/PCS Base Station Test Set Reference Guide* for more information about the RF Tools program.

Table 1-3 E6554A 8935 RF Tools Hardware Accessory Kit

Part	Part Number	Quantity	Use
Cable Assembly, N(M) to N(M), 2-ft.	8120-8687	2	Used to connect the Test Set to the VSWR bridge.
VSWR Bridge	0955-0829	1	Used to measure return loss
Termination, 50-ohm, N(M)	1250-2656	1	Used to terminate transmission lines.
Termination, short, N(M)	1250-2655	1	Used to terminate the DUT port of the VSWR bridge during return loss tests.
Resistive Power Splitter, 2-way	0955-0827	1	Divides one signal into two signals.
Adapter, BNC(M) to N(F)	1250-0077	2	Connects BNC cables to type N connections.
Attenuator, N(M) to N(F), 6-dB	0955-0826	2	Used during cable loss, insertion loss, and return loss tests.
Transit Case	E6554-61004	1	Organizes and safely transports kit contents.
Verification Guide	E6554-90001	1	Used as a checklist for accessory kit contents.

Product Description

Getting Help, Test Software Upgrades, and Training

For instrument servicing, see the *Agilent Technologies 8935 Series E6381A TDMA Test Set Assembly Level Repair Guide*.

For application assistance, call the Application Hotline (1-800-922-8920, USA and Canada only).

For information about Test Software upgrades and hands-on training, contact the local Agilent Technologies sales engineer.

2 Installation

This chapter describes the processes required to load and run the Test Software, connect the equipment, and make initial settings to configure the Test Set and the Test Software. *You must complete the procedures in this chapter before attempting measurements with the Test Software.*

Overview

The procedures included in this chapter are as follows:

1. [“Loading and Running the Test Software” on page 23.](#)
2. [“Navigating the Test Software” on page 25](#)
3. [“Operating the BTS Laptop Utility Program” on page 27.](#)

NOTE

BTS Laptop Utility program operation requires the use of a personal computer (PC) (usually a laptop PC). The use of a PC is not an absolute requirement, but the test examples in [Chapter 4, “Performing Tests,” on page 61](#) use a PC to control the cell site via the Mobile Switching Center (MSC). The Test Software also supports testing without PC control. If you elect not to use a PC with the Test System, skip the section that describes using the BTS Laptop Utility program and refer to [“Testing without MSC Control” on page 132](#) for a summary of differences when running without the PC.

4. [“Connecting the PC to the Test Set and the MSC” on page 32.](#)
5. [“Determining the Test Set to Site Equipment Connections” on page 36.](#)
6. [“Configuring the Test Software” on page 38.](#)
7. [“Defining a Frequency Plan” on page 45.](#)
8. [“Establishing a Connection with the MSC for Testing” on page 54.](#)

Loading and Running the Test Software

Locate the PC card labeled “Agilent Technologies E6559A Lucent AMPS/TDMA Base Station Test Software” and follow the steps outlined in [Figure 2-1](#) and [Figure 2-2](#).

Figure 2-1 Loading and Running the Test Software

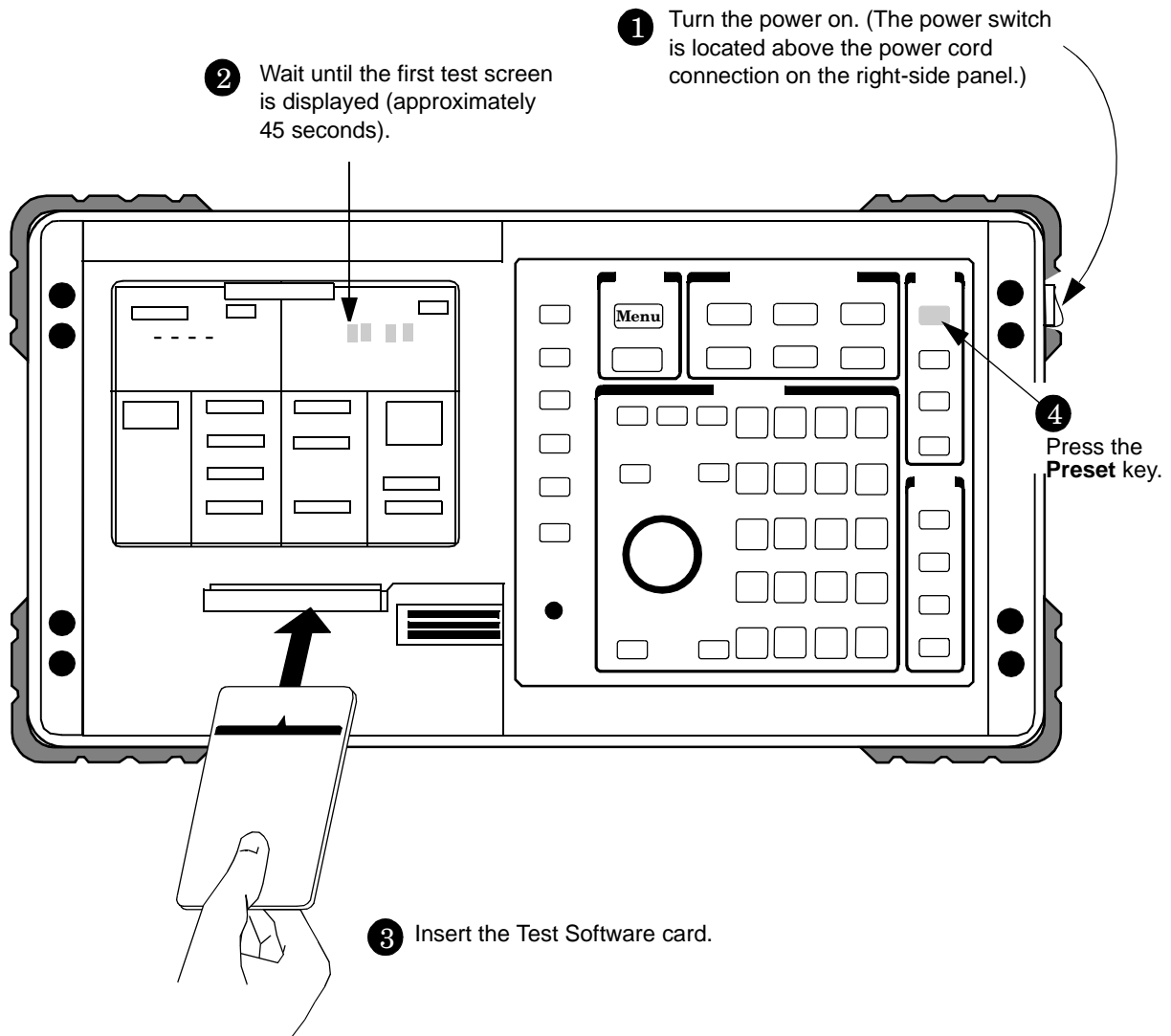
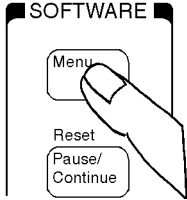













Figure 2-2 Loading and Running the Test Software (continued)

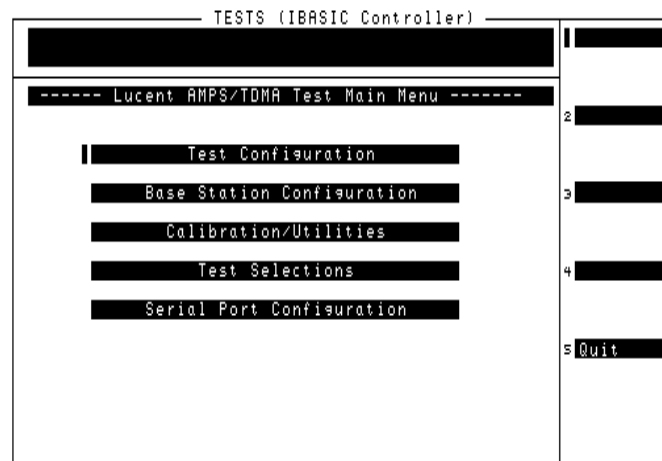
<p>5 Press the SOFTWARE Menu key to display the Lucent AMPS/TDMA Test Main Menu screen.</p> 	<p>6 Scroll to Select Procedure Location: and select it.</p> <p>Position</p>  <pre>LOAD TEST PROCEDURE: Select Procedure Location: █ Select Procedure Filename: █</pre> <p>Select</p> 
<p>7 Scroll to Card and select it.</p> <p>Position</p>  <pre>Choices: █ Card ROM RAM</pre> <p>Position</p> 	<p>8 Scroll to Select Procedure Filename: and select it.</p> <p>Position</p>  <pre>LOAD TEST PROCEDURE: Select Procedure Location: Card Select Procedure Filename: █</pre> <p>Select</p> 
<p>9 Scroll to Choices: and select the Procedure name.</p> <p>Position</p>  <pre>Choices: █ DEMO LTDMA</pre> <p>Select</p> 	<p>10 Scroll to Run Test and select it. The Test Software will load.</p> <p>Position</p>  <pre>1 Run Test 2 Continue 4 Help</pre> <p>Select</p>  <p>  Loading Time: First time: approximately 20 seconds. After first time: approximately 8 seconds.</p>

Navigating the Test Software

After the Test Software has loaded, the Lucent AMPS/TDMA Test Main Menu screen will appear on the Test Set display (see [Figure 2-3](#)).

Configuration operations, test utilities, and tests are grouped into sub-menus. Turn and press the knob to access the desired sub-menu.

Figure 2-3 Lucent AMPS/TDMA Test Main Menu Screen



Main Menu Functions

- **Test Configuration** – Define test information used by all tests; such as identifying the timing reference signal source, measurement port selection, number of averages, Walsh code power units, cable losses, and Base Station TX Test Port coupling factor.
- **Base Station Configuration** – Enter the specific cell site and Base Station information that the Test Software requires to control the Base Station when communicating with the MSC during tests (after configuring the PC and verifying its operation).
- **Calibration/Utilities** – Access procedures used to ensure optimal calibration of the Test Set and test cables.
- **Test Selections** – Access the available tests.
- **Serial Port Configuration** – Access routines used to define the serial port communication settings for interfacing with the PC serial port.

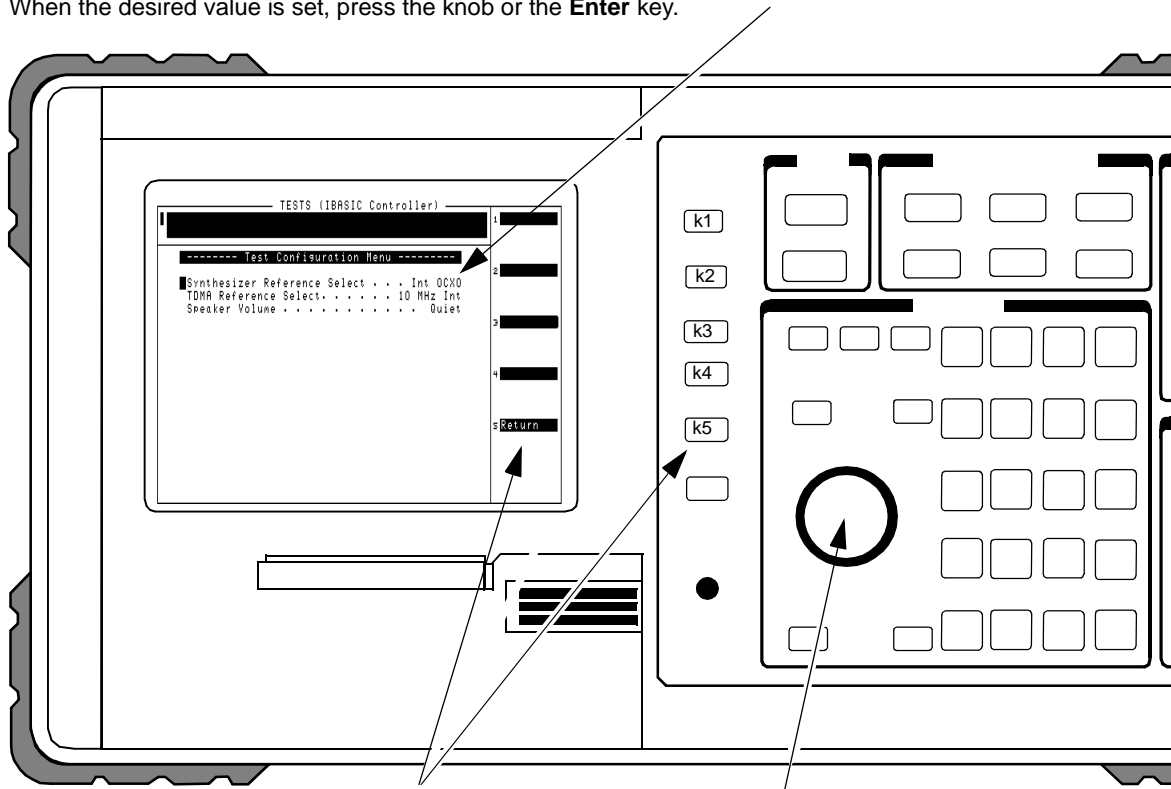
Changing Settings and Using USER Keys

See [Figure 2-4](#) for information on settings and USER keys.

Figure 2-4 Settings and USER Keys

Menu Selections

Some Menu selections are entry fields. When one of these is selected, a highlighted area appears and you may key in a value using the DATA keys, or rotate the knob to change the value in the field. When the desired value is set, press the knob or the **Enter** key.



USER Keys and Fields

The USER Keys (**k1 - k5**) correspond to fields 1-5 on the right side of the test screen. These keys are used for navigating through menus and for making selections. In many lower-level menus, a "Return" key is provided to display the previous screen.

Knob

The knob controls the cursor position on the display and is used sometimes to make numeric entries. Pressing the knob has the same effect as pressing the **Enter** key.

Operating the BTS Laptop Utility Program

The Test Software can control the cell site to perform tests in much less time than would be required under manual control. In order to control the Base Station, you may use a PC and modem to dial the MSC directly, or you may use a PC to establish a telnet connection to the MSC. The BTS Laptop Utility program running on that PC allows the Test Set to communicate with the MSC through the PC for automatic testing.

NOTE

The method of site control described in this section is optional, but is highly desirable when possible. If you elect to use other means of controlling the site equipment, some information about the Base Station is still required. Enter the appropriate information in the Base Station Configuration Menu screen (see [“Base Station Configuration” on page 41](#)), skip the rest of this chapter, and start testing (see [Chapter 4, “Performing Tests,” on page 61](#)). See also [“Testing without MSC Control” on page 132](#).

If you elect not to control the MSC using a PC, you may skip the rest of this chapter. Note however, that the procedures in [Chapter 4, “Performing Tests,” on page 61](#) use a PC for site control.

The BTS Laptop Utility program is shipped with the Test Software on two separate 3.5-inch diskettes. You must install the BTS Laptop Utility program on the PC to communicate with the MSC. The utility program also provides several other helpful functions.

The BTS Laptop Utility program provides the following window functions:

- **Switch Terminal** – A window that: 1) works with the PC internal modem to dial into the MSC, or with the PC and a telnet connection to the MSC, and 2) displays the information sent to and from the MSC.
- **Test Set Terminal** – A window in which you may view commands sent by the Test Set to the MSC.
- **Other Data** – A window from which to download frequency plans to the Test Set and in which short-form test results are displayed.
- **Test Results** – A window in which automated test results are displayed and may be saved for later use.
- **Test Set Screen Capture** – A window in which to capture screen images and save each as a bit mapped image. This is very helpful when using the Test Set spectrum analyzer or when you wish to capture some other screen. Note that IBASIC program operation must be paused first, by pressing the **Pause/Continue** key, to print any of the TESTS screens used for automated testing.

For more information on the windows in the above list, see [“BTS Laptop Utility Program Windows” on page 117](#). For additional information on using the BTS Laptop Utility program after installation, refer to the online Help topics included with that program.

System Requirements for BTS Laptop Utility Program

If the PC does not meet the following minimum system requirements, this could cause erratic operation and longer test times.

- 166-MHz Pentium® Processor
- 16 megabytes of RAM
- Windows® 95, Windows 98, or Windows NT 4.0 (Intel based)
- Available RS-232 serial port
- Internal modem

Installing the BTS Laptop Utility Program

The BTS Laptop Utility program comes compressed on two install diskettes for easy setup on the PC. Simply insert the first diskette into the drive, select **start** then **Run**, then type **A:\Setup**. The install shield will lead you through the installation process (see [Figure 2-5](#)).

Figure 2-5 Installing the BTS Laptop Utility Program



Configuring the Test Set and PC Serial Ports for Communication with the Test Set

After installing the BTS Laptop Utility program, you must configure the Test Set and PC serial ports to communicate with the Test Set.

Configure the serial ports as follows:

- Step 1.** On the Test Set, determine and record the Test Set SERIAL 9 port data transfer (baud) rate as follows:
- Load and run the Test Software (see “[Loading and Running the Test Software](#)” on [page 23](#)). The Test Software will display the Lucent AMPS/TDMA Test Main Menu screen.
 - Select the **Serial Port Configuration** field. The Test Software will display the Serial Port Configuration Menu screen.
 - Select the **Serial 9 Port Configuration** field. The Test Software will display the Serial 9 Port Configuration Menu screen.
 - Select and set the following Serial 9 Port Configuration Menu fields as appropriate for operation with the BTS Laptop Utility program.
 - **Baud Rate** – Select the field and then select a value from the drop-down **Choices:** list to match the Baud Rate setting in the BTS Laptop Utility program **Preferences, Comm Port Setup** drop-down window. The default value is 9600. However, the Test Software will operate more quickly at 19200, so it is recommended that you change the value to 19200.

NOTE

IMPORTANT: If you select a baud rate greater than 19200, the PC must remain connected to the Test Set or the Test Set will not operate properly, and might appear to be locked up.

- **Data Length** – Select the field and select 8 from the drop-down **Choices:** list.
- **Parity** – Select the field and select **None** from the drop-down **Choices:** list.
- **Stop Length** – Select the field and select 1 from the drop-down **Choices:** list.
- **Flow Control** – The default is **None**. If it is not set to the default, select the field and select **None** from the drop-down **Choices:** list.

NOTE

For optimum performance, use the following settings for **Flow Control**:

For baud rates ≤ 19200 , **Flow Control** should be set to **None**.

For baud rates >19200 , **Flow Control** should be set to **Hardware**.

- Step 2.** On the PC, determine and record the PC serial COM port designation (for example, COM1) from the Windows Device Manager Ports (COM & LPT) selection.
- Step 3.** On the PC, invoke the BTS Laptop Utility program. The BTS Laptop Utility program tool bar will appear on the PC display.
- Step 4.** Select **SW**, **TS**, **OD**, or **TR** (any one will do) from the BTS Laptop Utility program tool bar.
- Step 5.** Select **Preferences**, then **Comm Port Setup**.
- Step 6.** On the **Comm Port Setup** drop-down window, in the **Test Set - Port** list, select the port that the PC will use to communicate with the Test Set, as determined in Step 2.
- Step 7.** On the **Comm Port Setup** drop-down menu, in the **Test Set - Baud Rate** list, select the data transfer rate at which the PC will communicate with the Test Set, as determined in Step 1. This value will not automatically adjust during the session. The recommended baud rate for the Test Set is 19200.

Configuring the PC to Communicate with the MSC

After installing the BTS Laptop Utility program, if you are using the utility program to communicate with the MSC, you must configure the PC to do so. This may be done in either of two ways: 1) by using modem to dial the MSC directly, or 2) by using a telnet connection. The telnet connection may be either a dial-up Internet connection, or a direct Internet connection. The dial-up Internet connection would use the PC modem; the direct Internet connection would use a PC LAN (the most common of which is ethernet).

Modem Connection

If you elect to use a modem connection, configure the MSC connection as follows:

- Step 1.** On the PC, determine and record the PC modem port COM designation (for example, COM2) from the Windows Device Manager Modem selection.
- Step 2.** On the PC, invoke the BTS Laptop Utility program. The BTS Laptop Utility program tool bar will appear on the PC display.
- Step 3.** Select **SW**, **TS**, **OD**, or **TR** (any one will do) from the BTS Utility program tool bar.
- Step 4.** Select **Preferences**, then **Comm Port Setup**.
- Step 5.** On the **Comm Port Setup** drop-down menu, in the **Switch - Port** list, select the PC COM port assigned to the PC modem, as determined in Step 1.

If the modem port is already in use, the Test Software will display a message stating that a device already has control of that port. The most common cause is a communication program running in the PC background. Close the other program and reselect the required COM port.

- Step 6.** On the **Comm Port Setup** drop-down menu, in the **Switch - Baud Rate** list, select the data transfer rate at which the PC will communicate with the modem. Note that this is not the rate at which the modem will communicate with the MSC. Most modems negotiate at the start of the session with the modem on the other end of the line for the best data transfer rate. A typical setting is 57600.

Telnet Connection

If you elect to use a telnet connection, configure the MSC connection as follows:

- Step 1.** On the PC, invoke the BTS Laptop Utility program. The BTS Laptop Utility program tool bar will appear on the PC display.
- Step 2.** Select **SW**, **TS**, **OD**, or **TR** (any one will do) from the BTS Laptop Utility program tool bar.
- Step 3.** Select **Preferences**, then **Comm Port Setup**.
- Step 4.** On the **Comm Port Setup** drop-down menu, in the **Switch - Port** list, select **Telnet**.
- Step 5.** On the **Comm Port Setup** drop-down menu, the **Switch - Baud Rate** list is not active for a telnet connection. Make no selection.

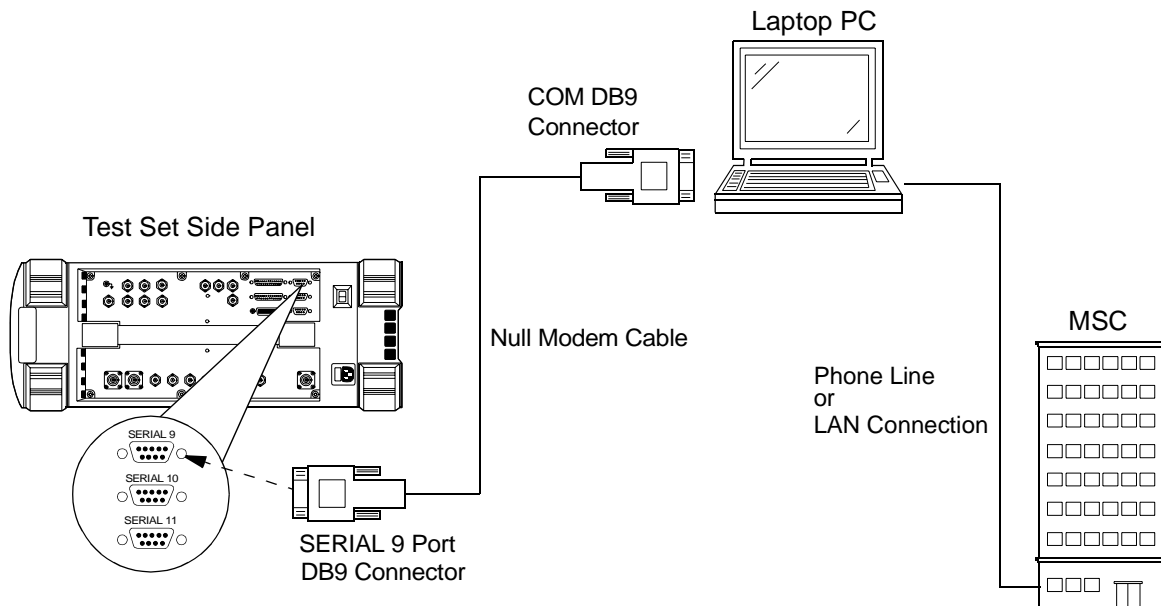
Connecting the PC to the Test Set and the MSC

The following sections describe the processes for connecting the PC to both the Test Set and the MSC.

Connecting the PC to the Test Set

Connect a null modem cable (DB9 to DB9) from the Test Set to the COM port of the PC as shown in [Figure 2-6](#).

Figure 2-6 Test Set to PC and PC to MSC Connection



At this point, you should be able to communicate with the Test Software.

To test the connection, configure the test set as follows, then attempt a screen capture.

NOTE

The screen capture function is inoperable while the Test Software is running. The Test Software must be paused.

- Step 1.** If the Test Software is running (a star appears in the upper right-hand corner of the display), press the **Pause/Continue** key to pause it.
- Step 2.** Press the Test Set **Shift** key, then the **Inst Config (I/O Config)** key. The Test Set will display the I/O CONFIGURE screen.
- Step 3.** Select the **serial_9 In** field and press the knob to toggle the setting to **Inst** (underlined).
- Step 4.** Press the Test Set **Shift** key, then the **Print (Printer Config)** key. The Test Set will display the PRINTER CONFIGURE screen.
- Step 5.** Select the **Model** field and select **DeskJet** from the drop-down **Choices:** list.

- Step 6.** Select the **Printer Port** field and select **Serial 9** from the drop-down **Choices:** list.
- Step 7.** With the cable connections complete and BTS Laptop Utility program running on the PC, press the Test Set **Print** key. The currently-displayed screen should appear in the **Test Set Screen Capture** window on the PC screen.

Connecting the PC to the MSC

After installing BTS Laptop Utility program on the PC, you must establish the connection between the PC and the MSC. This may be accomplished using either a direct dial-up modem connection or a telnet connection. These methods are described in the following sections.

Connect the PC to the MSC via a phone line or LAN connection as shown in [Figure 2-6](#)

Testing a Direct-Dial Modem Connection

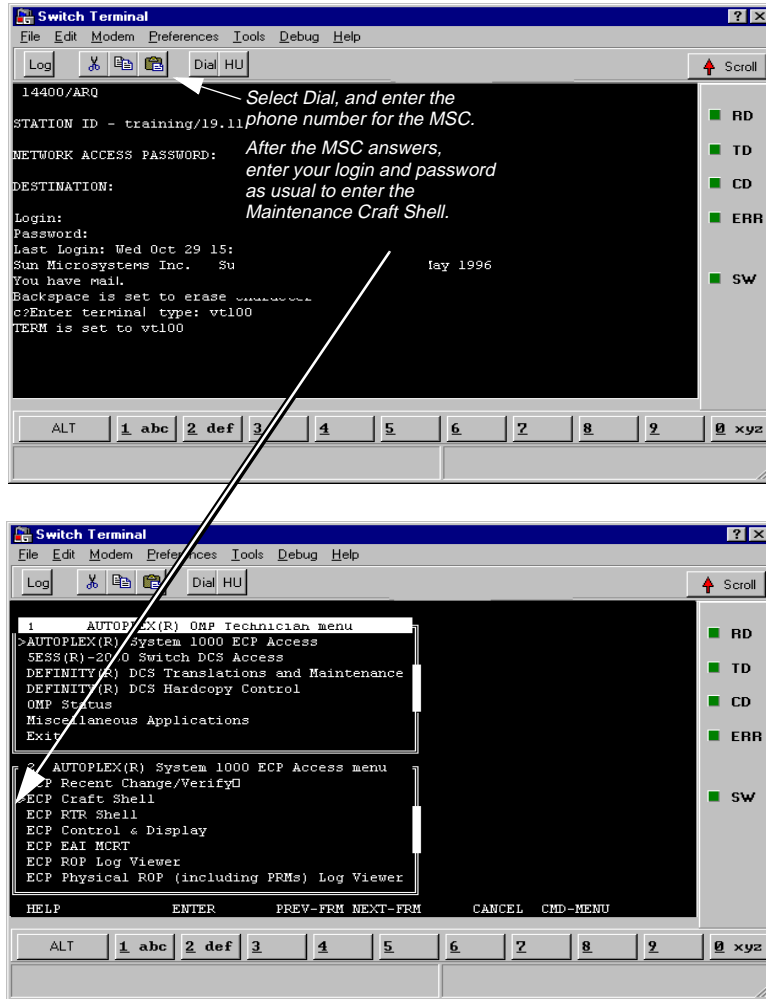
The PC modem must be connected to a phone line capable of connecting to the MSC. If no phone line is available at the Base Station, a wireless phone with a properly configured wireless-capable modem will suffice.

Test a modem connection as follows:

- Step 1.** From the BTS Laptop Utility program tool bar, select **SW**.
- Step 2.** In the **Switch Terminal** window, select **Dial**.
- Step 3.** In the drop-down **Dial** window, enter the MSC phone number, then select **OK** (see [Figure 2-7](#)).
- Step 4.** When prompted in the **Switch Terminal** window by the MSC, enter the same commands that you would use in your usual communication program to log in to the ECP. Once logged into the ECP, enter the maintenance craft shell. When you have finished, a command prompt will appear, which indicates that the MSC is waiting for the next command.

If you intend to start testing the Base Station soon, leave the MSC connection enabled. If some time will elapse before you start testing, log off from the MSC, and select the **Hangup/Disconnect (HU)** button in the **Switch Terminal** window.

Figure 2-7 Dialing and Logging Into the MSC Using the Switch Terminal Window



Testing a Telnet Connection

The telnet connection uses the Internet to connect to the MSC. You may use either a direct connection (using a LAN such as ethernet) or a dial-up connection (using the PC modem).

Test a telnet connection as follows:

- Step 1.** Use the PC to establish a telnet connection to the MSC according to your preferred method (direct or dial-up).
- Step 2.** From the BTS Laptop Utility program tool bar, select **SW**.
- Step 3.** In the **Switch Terminal** window, select **Dial**.
- Step 4.** In the drop-down **Dial** window, enter the IP address as the phone number, then select **OK** (see [Figure 2-7](#)).
- Step 5.** When prompted by the MSC in the **Switch Terminal** window, enter the same commands that you would use in your usual communication program to log in to the ECP. Once logged into the ECP, enter the maintenance craft shell. When you have finished, a command prompt will appear, which indicates that the MSC is waiting for the next command.

If you intend to start testing the Base Station soon, leave the MSC connection enabled. If some time will elapse before you start testing, log off from the MSC, and select the **Hangup/Disconnect (HU)** button in the **Switch Terminal** window.

Determining the Test Set to Site Equipment Connections

At this point in the process, you must decide the Test Set port and the Base Station port to be used in testing. At appropriate points in a test sequence, the Test Software will display prompts directing you to make connections. For details on the required connections, see [Chapter 3, “Connections,” on page 57](#).

Which Test Set Port to Use – ANT IN or RF IN/OUT?

CAUTION

The Test Set ANT IN port is only used for very low signal levels ≤ 60 milliwatts (17.78 dBm). Therefore, to prevent damage to the Test Set, *never connect this port directly to the Base Station TX Antenna Port*. This port is typically connected to the Base Station TX Test Port.

The Test Set RF IN/OUT port is for signals of ≤ 75 watts continuous wave or 60 watts TDMA. This is the only port on the Test Set that you should connect directly to the Base Station TX Antenna Port. If power levels from the Base Station exceed the specification of the port, use an appropriate signal attenuator.

Which Base Station Port to Use – TX Test or TX Antenna?

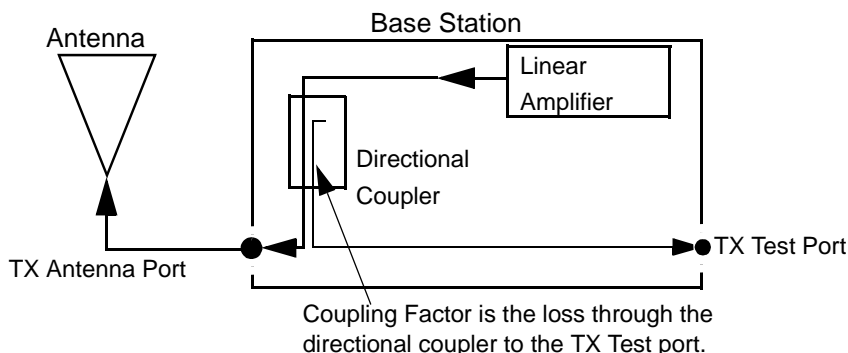
Testing may be performed while connected to either the Base Station Test Port or the Base Station Antenna Port. Although it results in a higher confidence level in the measurement, testing at the Antenna Port involves taking the Base Station out of service. The choices are described in the following sections.

In-Service Testing Using the Base Station TX Test Port

The Base Station TX Test Port signal is derived from the directional coupler that is connected between the Linear Amplifier and the Base Station TX Antenna Port (see [Figure 2-8](#)). This allows you to make measurements on an active Base Station without disconnecting the transmit antenna and interrupting service. You must enter a value for the coupling factor (loss) through the directional coupler to compensate power measurements (see [“Test Configuration” on page 39](#)). Coupling factors are typically 40 to 70 dB, but might vary, depending on the Base Station design.

Figure 2-8

Transmitter Output Path Simplified Diagram



If you are uncertain of the exact coupling factor, the Test Software contains a utility to measure the coupling factor (see “TX Test Port Coupling Measurements” on page 91).

NOTE

If you are uncertain of the Specified Output Power for the transmitter at the Base Station *TX Antenna Port*, the Test Software must measure the power to calculate the coupling factor. This requires that you take the Base Station out of service to connect the Test Set directly to the Base Station TX Antenna Port during the calibration routine.

One disadvantage to using the Base Station TX Test Port to make measurements is the possibility that its coupler is malfunctioning and therefore will cause erroneous measurements. If TX power measurements fail by a large amount, but you suspect the actual *transmitted* power is correct, take the Base Station out of service and make measurements directly at the Base Station TX Antenna Port to verify the failing reading. If the Test Software is correctly configured, TX power measurements using the Base Station TX Test Port and TX Antenna Port should not differ significantly.

Out-of-Service Testing Using the Base Station TX Antenna Port

Disconnecting a TX antenna feed line and connecting the Test Set to the Base Station TX Antenna Port (see [Figure 2-8](#)) requires that you first take the Base Station out of service (disable call processing and turn off all transmissions to that TX Antenna Port).

The Base Station may be taken out of service (and turned back on to make measurements) in two ways:

1. Access the MSC using a PC and the BTS Laptop Utility program to control the Base Station through its maintenance software.
2. Call the MSC and have switch personnel control the Base Station for you.

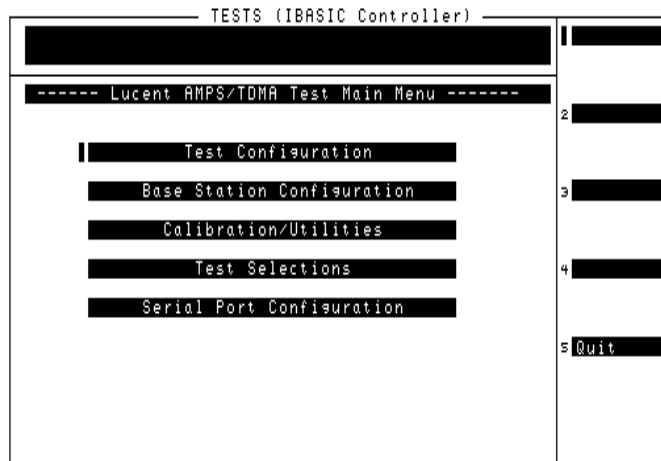
One benefit of testing directly at the Base Station TX Antenna Port is the confidence that the measurement will reflect the true output power of the Base Station at the point at which the antenna feed line connects to the Base Station. This verifies the operation of the full transmission path inside the Base Station. It also provides an opportunity to perform transmission line and antenna testing while the antenna is disconnected from the Base Station.

Configuring the Test Software

If the Test Software is not loaded and running, see “Loading and Running the Test Software” on page 23.

After the Test Software has loaded and is running, the Test Software will display the Lucent AMPS/TDMA Test Main Menu screen (see Figure 2-9). Configuration operations, test utilities, and tests are grouped into the listed sub-menus. Turn and press the knob to access the desired sub-menu.

Figure 2-9 Lucent AMPS/TDMA Test Main Menu Screen



- Step 3.** If you selected **TDMA Ref** in the step above, select the **TDMA Reference Select** field and select the TDMA analyzer timebase frequency from the drop-down **Choices:** list. The available selections are as follows:
- Select **25 Hz Ext**, **50 Hz Ext**, **24.3 kHz Ext**, **48.6 kHz Ext**, or **10 MHz Ext** to use an external timebase of the selected frequency, which must be connected to the TDMA REF IN connector. When a valid signal is detected the front panel **REFERENCE Unlock** indicator extinguishes and the **Ext TDMA** indicator lights.
 - Select **10 MHz Int** to use the Test Set internal 10-MHz timebase. This is the default setting, which must be used unless an external reference signal of the correct frequency and amplitude is applied to the TDMA REF IN connector.
- Step 4.** Select the **Speaker Volume** field and select from the drop-down **Choices:** list to set it to the desired level. The available selections are: **Off**, **Quiet**, and **Loud**. (This setting determines the volume of the beeps and tones issued by the Test Software during operation.)
- Step 5.** Press the **k5 (Return)** key to return to the Lucent AMPS/TDMA Test Main Menu screen.

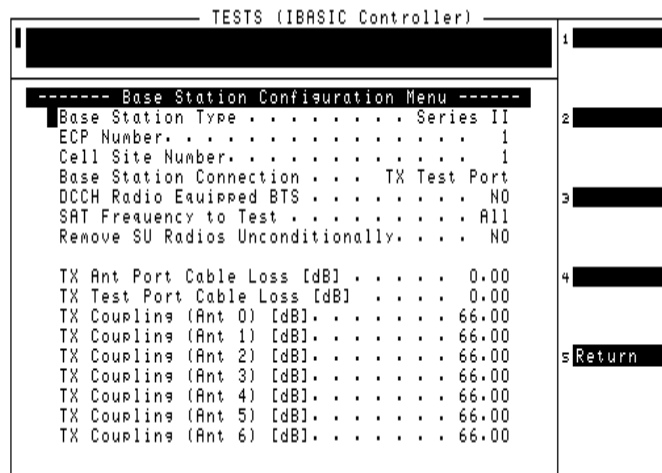
Base Station Configuration

Before the Test Software can control the Base Station, it must be able to notify the MSC as to the cell site and radio to test. The Test Software also requires information as to the Base Station type. You must supply this information on the Base Station Configuration Menu screen.

Configure the Base Station as follows:

- Step 1.** Select the **Base Station Configuration** field. The Test Software will display the Base Station Configuration Menu (see [Figure 2-11](#)).

Figure 2-11 Specifying Base Station Configuration Information



- Step 2.** Select the **Base Station Type** field and select the type of Base Station to be tested from the drop-down **Choices:** list. The available selections are: **Series II**, **M**, **MM**, and **PCS Minicell**.
- Step 3.** Select the **ECP Number** field, rotate the knob to the number for the ECP that controls the cell site to be tested, and press the knob to select it. (This field is not used in controlling the Base Station. It is used only for the test results forms.)
- Step 4.** Select the **Cell Site Number** field, rotate the knob to the number for the cell site to be tested, and press the knob to select it.
- Step 5.** Select the **Base Station Connection** field and select the test port to be used from the drop-down **Choices:** list.
- Select **TX Antenna Port** for out-of-service testing. In this mode, you must disconnect the antenna for the Base Station being tested and connect the Test Set RF IN/OUT port to the foam jumper from the Antenna Interface Frame (see [Figure 3-2 on page 59](#)).
 - Select **TX Test Port** for in-service testing. In this mode, you must connect the ANT IN port of the Test Set to the TX Test (coupled) port in the Antenna Interface Frame (see [Figure 3-1 on page 58](#)).

Step 6. Select the **DCCH Radio Equipped BTS** field and press the knob to toggle the field to reflect whether the Base Station includes DCCH radios. The selections are: **YES** and **NO**.

NOTE

If you selected **PCS Minicell** in the **Base Station Type** field, the following two fields (**SAT Frequency to Test** and **Remove SU Radios Unconditionally**) will not appear on the menu.

Step 7. Select the **SAT Frequency to Test** field and select the frequency (or frequencies) from the drop-down **Choices:** list. The available selections are: **5970 Hz**, **6000 Hz**, **6030 Hz**, or **All** (which tests all frequencies).

Step 8. If you plan to test an AMPS Setup radio (or perhaps several radios), you may elect to test the radio unconditionally, even if the MSC procedures would prefer that you not take the radio out of service. To do this, select the **Remove SU Radios Unconditionally** field, and press the knob to toggle it to **YES**.

Step 9. Select the **TX Ant Port Cable Loss [dB]** field and either turn the knob to the desired value and press the knob to select that value, or use the DATA ENTRY keys to enter a value and either press the **Enter** key or press the knob to select that value. This value is the loss through the cable used to connect the Test Set RF IN/OUT port to the end of the transmit antenna foam jumper out of the Antenna Interface Frame during out-of-service testing (see [Figure 3-2 on page 59](#)).

Step 10. Select the **TX Test Port Cable Loss [dB]** field and either turn the knob to the desired value and press the knob to select that value, or use the DATA ENTRY keys to enter a value and either press the **Enter** key or press the knob to select that value. This is the loss through the cable used to connect the Test Set ANT IN port to the coupled test port in the Antenna Interface Frame during in-service testing (see [Figure 3-1 on page 58](#)).

Step 11. Select the **TX Coupling** field for each Base Station TX Test Port in the Antenna Interface Frame and enter the coupling factor to be used during tests. To do this, either turn the knob to the desired value and press the knob to select that value, or use the DATA ENTRY keys to enter a value and either press the **Enter** key or press the knob to select that value. If you do not know the coupling factor(s), run the [“TX Test Port Coupling Measurements” on page 91](#) to measure it.

Step 12. Press the **k5 (Return)** key to return to the Lucent AMPS/TDMA Test Main Menu screen.

Printing the FCC Title Page

After entering the information on the Base Station Configuration screen, you may print a title page that indicates the testing conditions used. This will provide a record for later use when comparing test results and conditions for each cell site.

To print the title page:

- Step 1.** Connect a PC on which the BTS Laptop Utility program is installed, configured, and running (see [“Operating the BTS Laptop Utility Program” on page 27](#)).
- Step 2.** Load and run the Test Software (see [“Loading and Running the Test Software” on page 23](#)).
- Step 3.** From the Lucent AMPS/TDMA Test Main Menu screen, select the **Calibration/Utilities** field.
- Step 4.** In the **Other Data** window, select the **Log** button (toggle it to “on”) to enable logging. The **Log Filename** window will appear.
- Step 5.** In the **Log Filename** window, select the location to which to save the file, enter the file name in the **File name** field (using a *.txt* extension), and select the **Save** button. The frequency plan file will be saved to the selected location.
- Step 6.** Select the **Print FCC Title Page** field. The BTS Laptop Utility program will print the title page in the **Other Data** window.
- Step 7.** Close the log file by selecting the **Log** button again (to toggle it to “off”).
- Step 8.** Print the file from the PC using a word processor (see [Figure 2-12](#)).

Figure 2-12 **FCC Title Page Printout**

Page 1 of _____

CELL SITE FCC RECORD

Cell Site Identification: 1 Operator's Signature _____

Equipment Used: Hewlett-Packard.8935.000000US37120006.A.01.52

Equipment calibration Date _____

Date [MM/DD/YY] 082198 Time [HH.MM] 14.29

Lucent AMPS Base Station Tests

Coupling between TX Test Port and TX Antenna Port 0: 66.00 dBm

Coupling between TX Test Port and TX Antenna Port 1: 66.00 dBm

Coupling between TX Test Port and TX Antenna Port 2: 66.00 dBm

Coupling between TX Test Port and TX Antenna Port 3: 66.00 dBm

Coupling between TX Test Port and TX Antenna Port 4: 66.00 dBm

Coupling between TX Test Port and TX Antenna Port 5: 66.00 dBm

Coupling between TX Test Port and TX Antenna Port 6: 66.00 dBm

TX antenna 0: Gain _____ dB Cable loss _____ dB

TX antenna 1: Gain _____ dB Cable loss _____ dB

TX antenna 2: Gain _____ dB Cable loss _____ dB

TX antenna 3: Gain _____ dB Cable loss _____ dB

TX antenna 4: Gain _____ dB Cable loss _____ dB

TX antenna 5: Gain _____ dB Cable loss _____ dB

TX antenna 6: Gain _____ dB Cable loss _____ dB

Defining a Frequency Plan

When running the Full Cell Site Test mode (see “Full Site Test (FCC)” on page 67), you must provide information to the Test Software on the radios in the site being tested. This is done using frequency plans. Frequency plans are defined on a per site basis. There must be one plan for each site to be tested.

Once a plan is defined, you may store it on an SRAM card for later use for modification.

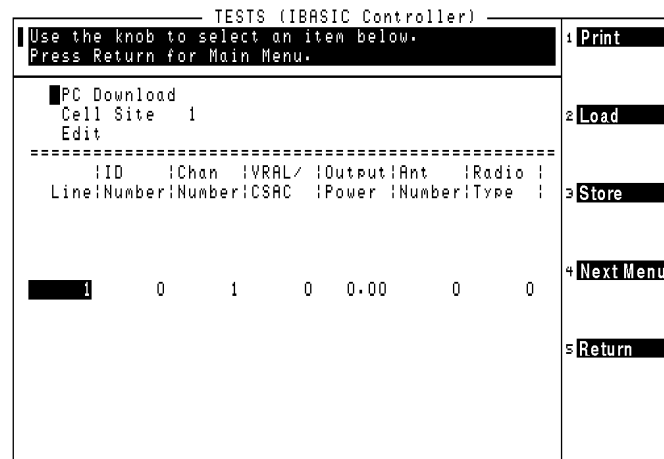
The Test Software supports two methods for entering the information into a frequency plan. The first method uses an editor that is part of the Test Software. In this method, all plan entry is done on the Test Set front panel. The second method uses an external PC with an editing program. In this method, the plan is defined and then downloaded to the Test Set for storage.

Defining a Frequency Plan Using the Editor in the Test Software

The process of defining a frequency plan using the editor function of the Test Software requires saving the frequency plan on an SRAM card. Before beginning the plan definition, make certain that an initialized SRAM card is available for file storage.

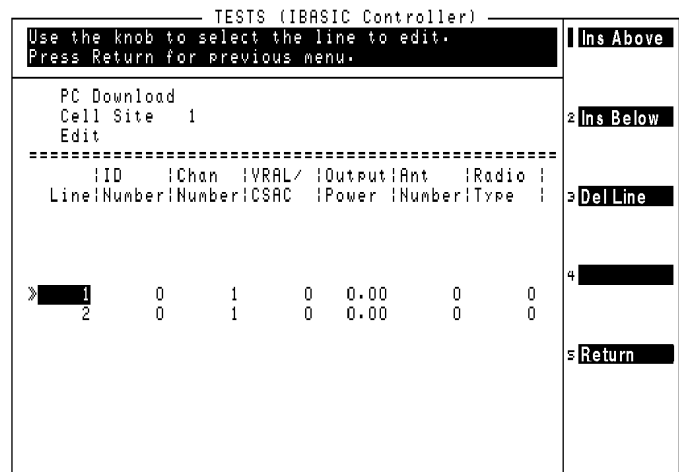
- Step 1.** From the Lucent AMPS/TDMA Test Main Menu screen, select the **Calibration/Utilities** field. The Test Software will display the Calibration/Utilities Menu screen.
- Step 2.** Select the **Define Frequency Plan** field. The Test Software will display the Define Frequency Plan screen (see Figure 2-13). Note that the display is divided into two parts. The top of the screen is used to perform file functions, and the lower part is used to edit the data. Scroll to the **Cell Site** field and enter the number of the site for which the plan is to be defined. To do this, either turn the knob to the desired site number and press the knob to select that number, or use the DATA ENTRY keys to enter a site number and either press the **Enter** key or press the knob to select that number.

Figure 2-13 Defining a Frequency Plan



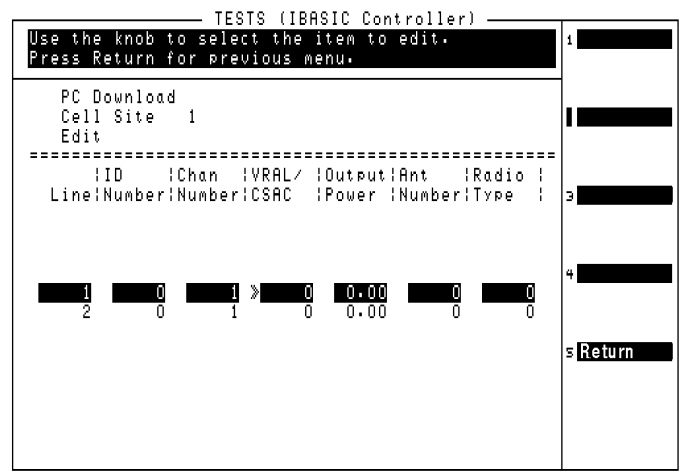
- Step 3.** Select the **Edit** field to activate the lower part of the screen for editing. The first line will show a highlighted one (1). Note that the USER key assignments on the right side of the screen also changed to allow you to insert or delete lines of frequency plan information.
- Step 4.** Press the **K1 (Ins Above)** key to add lines to the list (see [Figure 2-14](#)). Each line of the plan corresponds to one radio in the site.

Figure 2-14 Adding Lines to the Frequency Plan



- Step 5.** Press the knob to highlight the seven entries for that line in the plan (see [Figure 2-15](#)). You may then modify the entries for that line by moving the cursor to the left of each entry, pressing the knob, and changing the value using the DATA ENTRY keys or the knob. After changing an entry, press the knob again to move to the next entry.

Figure 2-15 Changing Entries in the Frequency Plan



Step 6. Use the **Line** field to select each line in the plan (which corresponds to individual radios in the site), and then enter these values for each line:

- **ID Number** — the Radio ID number (0 to 199)
- **Chan Number** — the radio channel number (1 to 1023)
- **VRAL/CSAC** — the Voice RAdio Level (VRAL) for an AMPS radio, or the Control Setup Attenuation Code (CSAC) for an AMPS Setup radio. Range is 0 to 7.
- **Output Power** — the power at the TX antenna output from the Antenna Interface Frame.
- **Ant Number** — the antenna number for that radio (0 to 6) (see [Table 2-1](#)).
- **Radio Type** — 0=AMPS radio, 1=AMPS Setup radio, 2=TDMA Voice radio, 3=TDMA DCCH radio.

Table 2-1 Antenna Numbers and Equivalents

Ant # Entry	Antenna Equivalent (typical)
0	Omni antenna
1	Alpha face of a sectored site
2	Beta face of a sectored site
3	Gamma face of a sectored site
4	Delta face of a six-sectored site
5	Epsilon face of a six-sectored site
6	Zeta face of a six-sectored site

Step 7. This completes the definition of the frequency plan for one site (see [Figure 2-16](#)). Press the **k5 (Return)** key to exit the editing mode.

Figure 2-16 Example Frequency Plan

```

TESTS (IBASIC Controller)
Use the knob to select the line to edit.
Press Return for previous menu.

PC Download
Cell Site 1
Edit
=====
!ID !Chan !VRAL/ !Output!Ant !Radio !
Line!Number!Number!CSAC !Power !Number!Type !
1 199 332 3 7.00 0 1
> 2 198 777 0 5.50 0 0
3 197 969 0 5.50 0 0
4 196 1001 0 5.50 0 0
1 Ins Above
2 Ins Below
3 Del Line
4
5 Return

```

Installation

Step 8. Insert an initialized SRAM card into the Test Set front panel card slot, and press the **k3** (**Store**) key to store the plan. Store the plan using the **Cell Site** number entry.

Step 9. If you wish to define plans for other sites, repeat **step 2** through **step 8** for each site. Otherwise, press **k5** (**Return**) to return to the Calibration/Utilities Menu.

Defining a Frequency Plan Using a PC

You may create a frequency plan using a PC and then download that plan to the Test Set. A plan created using a PC may be saved, reused, and updated as necessary.

Requirements

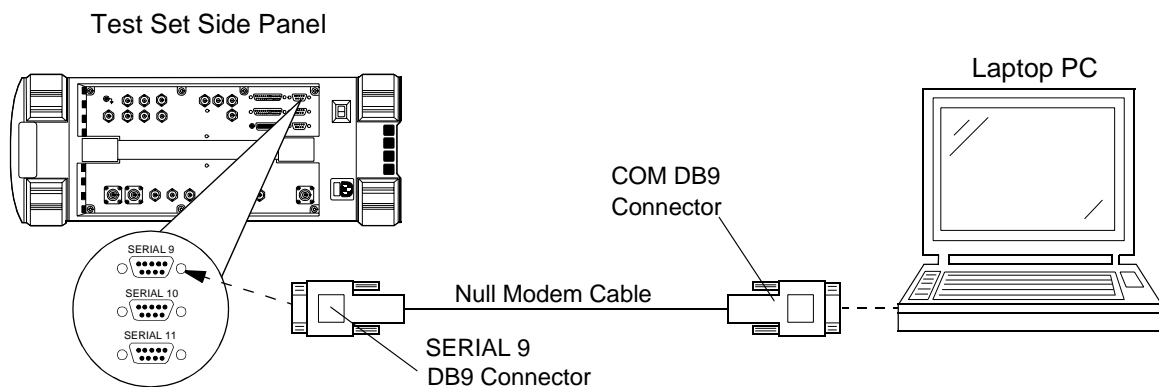
- A PC with an available serial communications port.
- A PC program for text editing (such as Windows Notepad) and a program for serial communications (such as the BTS Laptop Utility program shipped with the Test Set Software).
- A null modem cable for connecting the Test Set to the PC.
- Optional – An initialized SRAM card for storing the frequency plans once defined.

Test Set to PC Connection

If you have not done so already, configure the PC to communicate with the Test Set (see [“Configuring the Test Set and PC Serial Ports for Communication with the Test Set” on page 29](#)).

Connect the Test Set and the PC for serial connection in the same manner the same as that used for testing the radio with a connected PC (see [Figure 2-17](#)).

Figure 2-17 Test Set to PC Serial Connection



Create the Frequency Plan File

You may use any text editor that allows you to save a file in an ASCII format to create a frequency plan. The following procedure outlines the process for creating a text file to download to the Test Set:

NOTE

If necessary, refer to the documentation for the PC application software for details on opening new files, entering data, and storing the file.

- Step 1.** Start the text editor program on the PC.
- Step 2.** Open a new file to begin editing.
- Step 3.** The guidelines for creating a plan for one site are as follows:
 - You may enter the data in one long string or in a tabular format.
 - Separators between numbers (delimiters) may be spaces, commas, periods, tabs, or another non-numeric character. Enter a carriage return (Line feed, Return/Enter, and so forth) and at least one alpha character after the last number in the last line in the plan to define the end point of the plan.
 - You may use text anywhere in the file to keep track of the numbers in the file. When downloading the file to the Test Set, all non-numeric text is ignored (with the exception of the carriage return, and alpha character to indicate the end of the plan during the transfer).
 - The first number in the file should be the Cell Site Number.
 - The next line must contain values that match the Define Frequency Plan screen fields (**Line**, **IC Number**, **Chan Number**, **VRAL/CSAC**, **Output Power**, **Ant Number** (see [Table 2-1 on page 47](#)), and **Radio Type** (0=AMPS, 1=AMPS Setup, 2=TDMA Voice, 3=TDMA DCCH). See [Figure 2-18](#) for an example of a frequency plan definition. Again, the text is optional and you may use other text or none at all.
 - Add additional lines for each additional radio, again making sure that data for each field is entered.
 - Increment the **Line** field by one for each additional line you use.

Figure 2-18 Example Frequency Plan on the PC

The Cell Site number must be the first numeric character.

```

Cs200 - Notepad
File Edit Search Help
Frequency Plan: Cell Site 200
LINE  ID    CHAN  VRAL/CSAC  PWR  ANT  TYPE
1     123   777   3          5.5  2    1
2     118   790   2          5.9  2    0
3     117   803   2          5.7  2    0
END|
  
```

Always include at least one alpha character on a separate line after the last *numeric* character to indicate to the Test Software that the end of the last line is completed.

Installation

- Step 4.** Once the entries match the site configuration, save the file in an ASCII format using the extension *.txt* (for example: CS200.txt).
- Step 5.** If you wish to define plans for more than one site, repeat **step 2** through **step 4** until plans for all sites have been created and saved.
- Step 6.** Exit the editing program.

Send the Plan to the Test Set

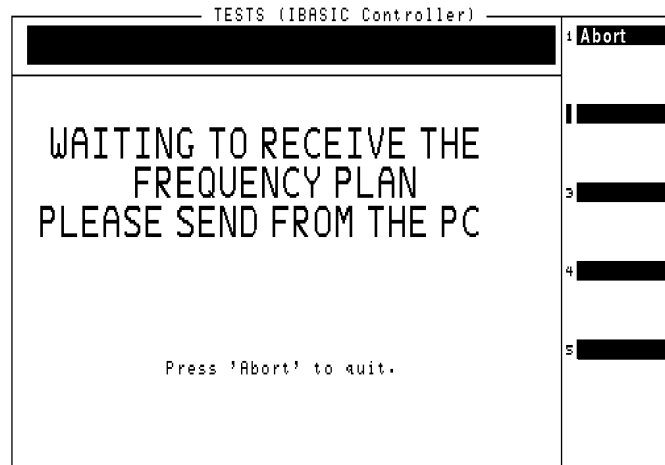
Once you have connected the Test Set to the PC via the serial port and defined and saved a frequency plan, you may send the plan to the Test Set. The following procedure uses the BTS Laptop Utility program (shipped with the Test Software) to perform this function.

NOTE

If you elect not to use the BTS Laptop Utility, refer to the documentation for the PC communication program for details on setting up serial communications, opening files, and transferring data.

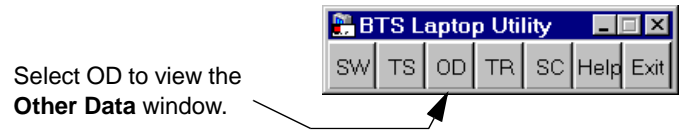
- Step 1.** From the Lucent AMPS/TDMA Test Main Menu screen, select the **Calibration/Utilities** field. The Test Software will display the Calibration/Utilities Menu screen.
- Step 2.** Select the **Define Frequency Plan** field. The Test Software will display the Define Frequency Plan screen.
- Step 3.** Select the **PC Download** field. The Test Software will display the screen shown in [Figure 2-19](#) to indicate that it is ready to receive the frequency plan.

Figure 2-19 Test Software Ready Screen



- Step 4.** Load and run the BTS Laptop Utility program as explained in [“Operating the BTS Laptop Utility Program”](#) on page 27. When the program is running, the BTS Laptop Utility tool bar will appear on the PC screen (see [Figure 2-20](#)).

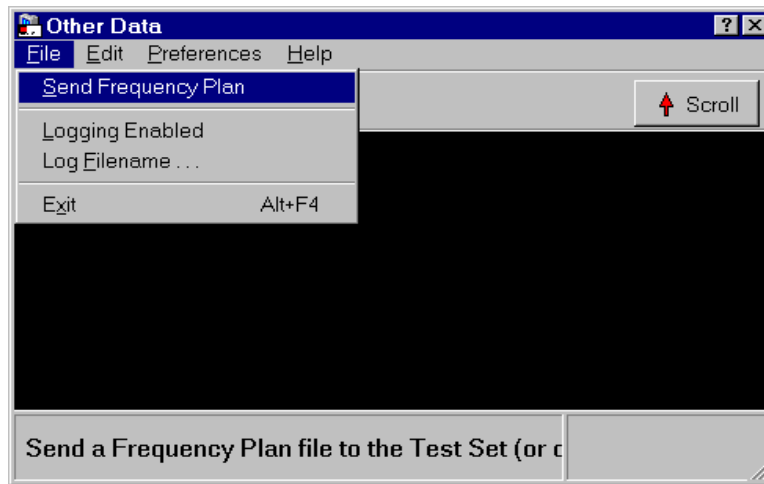
Figure 2-20 **BTS Laptop Utility Program Tool Bar**



Step 5. Open the **Other Data** window by selecting the **OD** button on the tool bar.

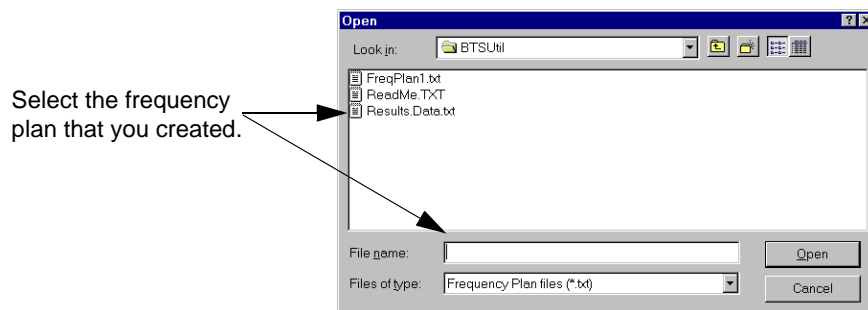
Step 6. In the **Other Data** window (see [Figure 2-21](#)), select **File**, then **Send Frequency Plan**.

Figure 2-21 **Other Data Window**



Step 7. Select the frequency plan file that you saved (see [Figure 2-22](#)). Double-click on the file name, or select the file name and select **Open**. The frequency plan will be downloaded to the Test Software.

Figure 2-22 **Selecting the Saved Frequency Plan**



Step 8. If all is set up correctly, transmitted characters should scroll on the Test Set screen. After a pause, the Test Software will return to the Define Frequency Plan screen and the transferred plan will be displayed.

NOTE If you wish to store the frequency plan data on an SRAM card, perform the next step. If not, skip the next step.

Step 9. With the correct cell site number and frequency plan data displayed, insert an initialized SRAM card into the Test Set and press the **k3 (Store)** key. The new frequency plan will be stored for that cell site number.

NOTE If you change the cell site number before storing, *the data will be lost.*

Step 10. If you have additional files to transfer for defining other sites, repeat **step 3** through **step 9** until all files have been sent to the Test Set (and stored to the card if you elected to do so).

Step 11. To exit the **Define Frequency Plan** menu, press the **k5 (Return)** key.

Loading a Frequency Plan from an SRAM Card

Frequency plans may be loaded from an SRAM card. Load the files from the SRAM card as follows:

1. Insert the SRAM memory card with the frequency plan to be loaded.
2. From the Lucent AMPS/TDMA Test Main Menu screen, select the **Calibration/Utilities** field. The Test Software will display the Calibration/Utilities Menu screen.
3. Select the **Define Frequency Plan** field. The Test Software will display the Define Frequency Plan screen.
4. Scroll to the **Cell site** field, press the knob, and enter the number of the site that corresponds to the file that you wish to load. To do this, turn the knob to the desired site number and press the knob to select that number, or use the DATA ENTRY keys to enter a site number and either press the **Enter** key or press the knob to select that number. If the card has a plan for that site, the data will be loaded automatically when you enter the number.

NOTE If you edit a saved plan on the Test Set and then decide *not* to make the changes, **if you have previously saved the plan to the SRAM card**, simply press the **k2 (Load)** key and the on-screen data will be overwritten with numbers from the card.

Purging (Deleting) a Frequency Plan File

Frequency plans may be maintained by editing existing files. If there are plans that are no longer of use, however, you may purge (delete) the files from the SRAM card as follows:

Step 1. Insert the SRAM memory card with the frequency plan to be purged.

Step 2. From the Lucent AMPS/TDMA Test Main Menu screen, select the **Calibration/Utilities** field. The Test Software will display the Calibration/Utilities Menu screen.

Step 3. Select the **Define Frequency Plan** field. The Test Software will display the Define Frequency Plan screen.

- Step 4.** Scroll to the **Cell Site** field, press the knob, and enter the number of the site that corresponds to the file that you wish to delete. To do this, turn the knob to the desired site number and press the knob to select that number, or use the DATA ENTRY keys to enter a site number and either press the **Enter** key or press the knob to select that number.
- Step 5.** Press the **k4 (Next Menu)** key to access additional file operations.
- Step 6.** Press the **k2 (Purge)** key.
- Step 7.** The Test Software will display a query asking you to verify the purge operation for the cell site number entered. Press the **k1 (Yes)** key to purge the file.
- Step 8.** Press the **k5 (Return)** key twice to return to the Lucent AMPS/TDMA Test Main Menu screen.

Printing a Frequency Plan

If a PC with the BTS Laptop Utility program is connected to the Test Set, you may print frequency plans to the BTS Laptop Utility **Other Data** window. This can be useful for record-keeping. Print frequency plans as follows:

- Step 1.** Make certain that the BTS Laptop Utility program is loaded and running on the PC (see [“Operating the BTS Laptop Utility Program” on page 27](#)).
- Step 2.** From the Test Software Main Menu screen, select the **Calibration/Utilities** field. The Test Software will display the Define Frequency Plan screen.
- Step 3.** Select the **Define Frequency Plan** field.
- Step 4.** If the frequency plan that you wish to print is not currently loaded, insert the SRAM card containing the plan and select the plan by scrolling to **Cell Site**, pressing the knob, and entering the site number that corresponds to the plan of interest. The frequency plan data will be loaded automatically when you enter the number.
- Step 5.** In the **Other Data** window, select the **Log** button (toggle it to “on”) to enable logging. The **Log Filename** window will appear.
- Step 6.** In the **Log Filename** window, select the location to which to save the file, enter the file name in the **File name** field (using a *.txt* extension), and select the **Save** button. The frequency plan file will be saved to the selected location.
- Step 7.** Press the **k1 (Print)** key to send the frequency plan information to the **Other Data** window.
- Step 8.** Close the log file by selecting the **Log** button again (to toggle it to “off”).
- Step 9.** Print the file from the PC using a word processor.
- Step 10.** If you would like to print other plans, change the **Cell Site** field in the Define Frequency Plan screen to the appropriate number and repeat [step 4](#) through [step 9](#).
- Step 11.** When finished, press **k5 (Return)** twice to return to the Lucent AMPS/TDMA Test Main Menu screen.

Establishing a Connection with the MSC for Testing

If it is not set up already, you must establish the connection between the PC and the MSC. This may be accomplished using either a direct dial-up modem connection or a telnet connection. These methods are described in the following sections.

Connect the PC to the MSC via a phone line or LAN connection as shown in [Figure 2-6 on page 32](#).

Establishing a Direct-Dial Modem Connection

The PC modem must be connected to a phone line capable of connecting to the MSC. If no phone line is available at the Base Station, a wireless phone with a properly configured wireless-capable modem will suffice.

Test a modem connection as follows:

- Step 1.** From the BTS Utility program tool bar, select **SW**.
- Step 2.** In the **Switch Terminal** window, select **Dial**.
- Step 3.** In the drop-down **Dial** window, enter the MSC phone number, then select **OK** (see [Figure 2-7 on page 34](#)).
- Step 4.** When prompted by the MSC in the **Switch Terminal** window, enter the same commands that you would use in your usual communication program to log in to the ECP. Once logged into the ECP, enter the maintenance craft shell. When you have finished, a command prompt will appear, which indicates that the MSC is waiting for the next command.

Establishing a Telnet Connection

The telnet connection uses the Internet to connect to the MSC. You may use either a direct connection (using a LAN such as ethernet) or a dial-up connection (using the PC modem).

Test a telnet connection as follows:

- Step 1.** Use the PC to establish a telnet connection to the MSC according to your preferred method (direct or dial-up).
- Step 2.** From the BTS Utility program tool bar, select **SW**.
- Step 3.** In the **Switch Terminal** window, select **Dial**.
- Step 4.** In the drop-down **Dial** window, enter the IP address as the phone number, then select **OK** (see [Figure 2-7 on page 34](#)).
- Step 5.** When prompted by the MSC in the **Switch Terminal** window, enter the same commands that you would use in your usual communication program to log in to the ECP. Once logged into the ECP, enter the maintenance craft shell. When you have finished, a command prompt will appear, which indicates that the MSC is waiting for the next command.

If You Noticed Problems

If you were unable to load and run the Test Software, make the required entries, or encountered error messages, refer to [Chapter 6, “Troubleshooting,” on page 135](#) for help.

3 **Connections**

This chapter shows the connections between the Test Set and the Base Station.
The Test Software will display a screen prompt whenever a connection or a change in connections is required.

Test Set to Base Station Connections

Figure 3-1 and Figure 3-2 show connections between the Test Set and the Base Stations.

Figure 3-1 Series II Base Station Test Port (In Service) Connections

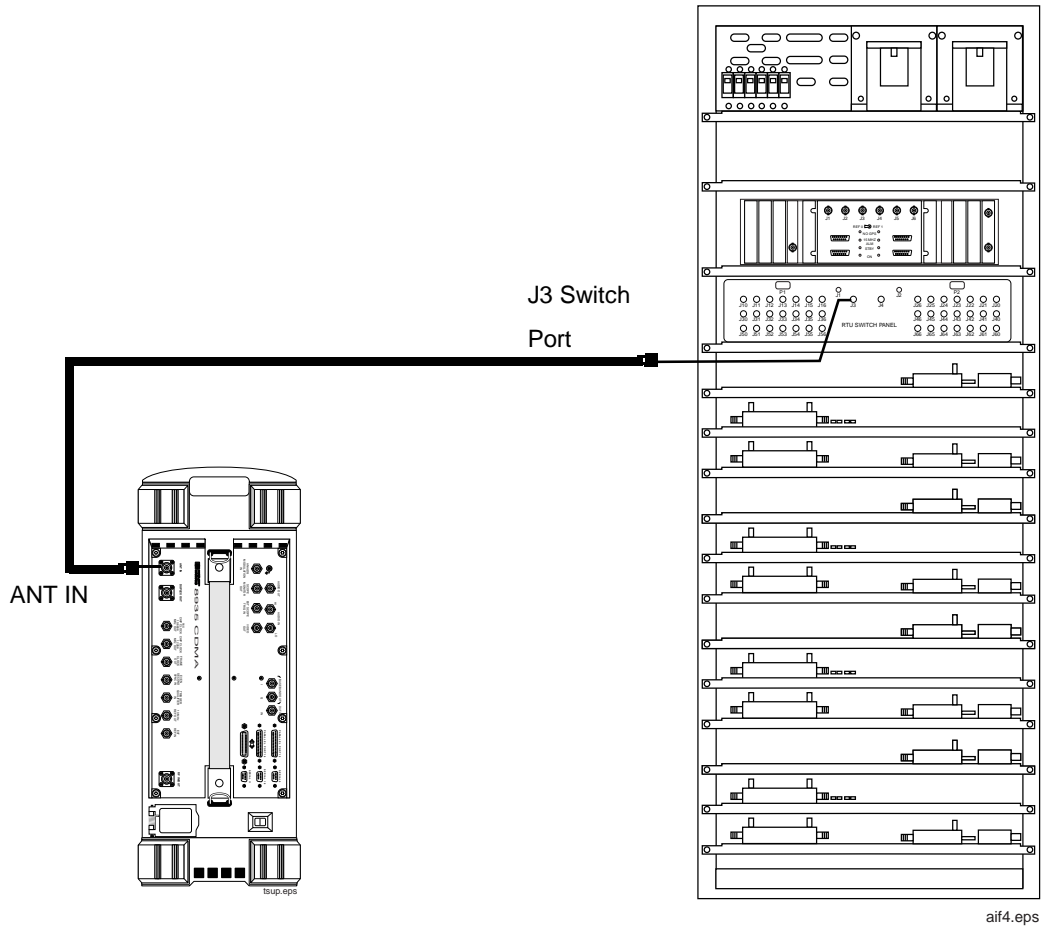
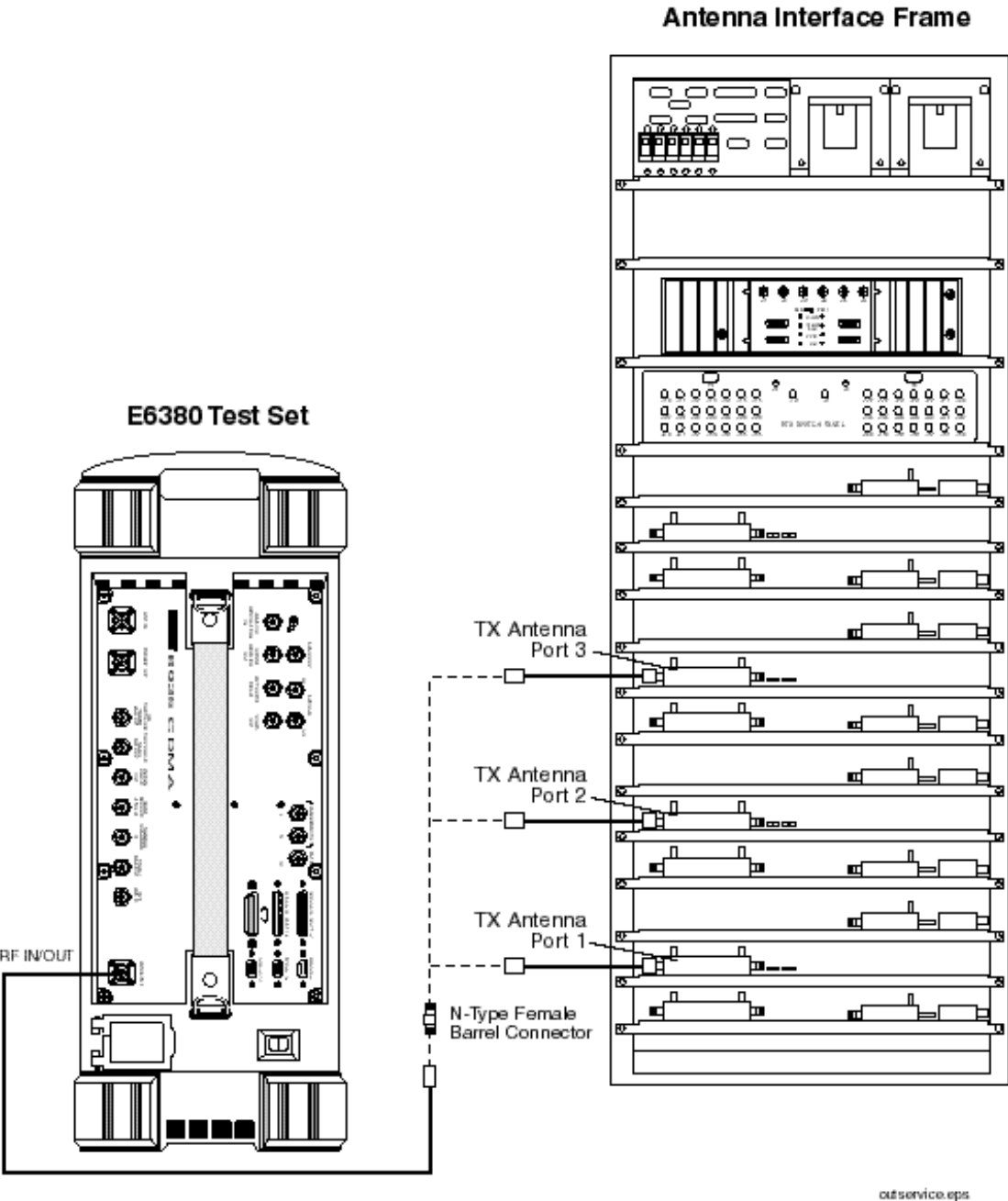


Figure 3-2 Series II Base Station TX Antenna Port (Out of Service) Connections



4 Performing Tests

This chapter describes detailed procedures to be used in running the Test Software tests and utilities.

Overview

NOTE

Testing might be interrupted if cell site diagnostics are initiated by the MSC while tests are being run. To prevent this, use a personal computer (PC) (usually a laptop PC) to send a command to inhibit diagnostics from the MSC before testing.

These test procedures describe the process from setting up a test to obtaining test results. To simplify the procedures, all are written to use a PC to communicate with the MSC (where applicable) and the Test Software will be set to send control commands.

Before making measurements, verify that you have performed the following setup and configuration processes:

- [“Loading and Running the Test Software” on page 23.](#)
- [“Operating the BTS Laptop Utility Program” on page 27.](#)
- [“Connecting the PC to the Test Set and the MSC” on page 32.](#)
- [“Configuring the Test Software” on page 38.](#)
- [“Defining a Frequency Plan” on page 45.](#)
- [“Establishing a Connection with the MSC for Testing” on page 54.](#)

Calibrating the Test Setup

If you did not know the Base Station TX Antenna Port Cable Loss, or the Base Station TX Test Port Cable Loss, or the Base Station TX Coupler Losses when you entered the data on the Base Station Configuration Menu screen, run the following calibration routines to determine these losses. Determining these losses is crucial to obtaining accurate test results.

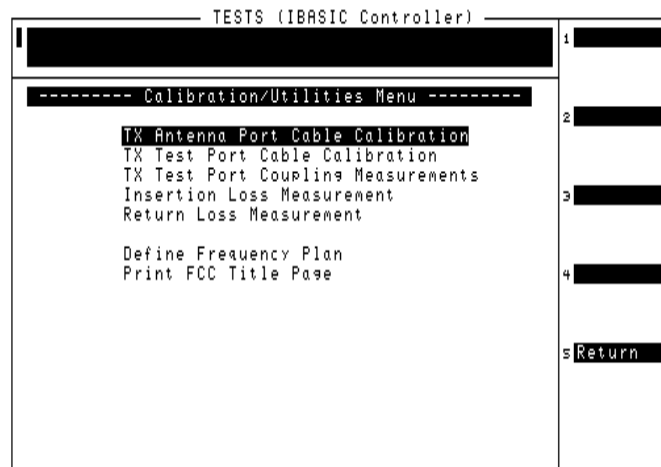
Access these routines by loading and running the Test Software (see [“Loading and Running the Test Software” on page 23](#)) and selecting **Calibration/Utilities** from the Lucent AMPS/TDMA Tests Main Menu screen. The Test Software will display the Calibration/Utilities Menu screen (see [Figure 4-1](#)). After each measurement, the program will enter the value automatically into the Test Software for future testing (without your having to rerun the routines every time that you test). However, if you run a different program after the measurements, you must re-measure (or re-enter) the values the next time that you use the Test Software.

The Calibration procedures are:

- [“TX Antenna Port Cable Calibration” on page 87](#). Run this utility to determine antenna port cable losses at the frequency and power level at which testing will be performed.
- [“TX Test Port Cable Calibration” on page 89](#). Run this utility to determine test port cable losses at the frequency and power level at which testing will be performed.
- [“TX Test Port Coupling Measurements” on page 91](#). Run this utility to determine the exact coupling factor (loss) of the Base Station TX Test Port.

Figure 4-1

Calibration/Utilities Menu Screen



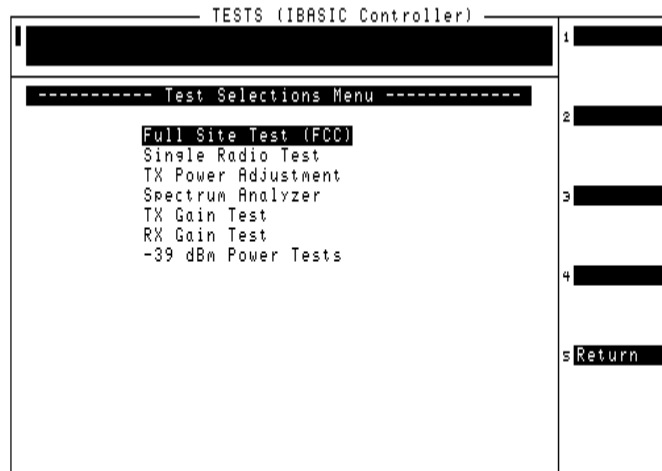
Selecting Tests

Select tests by loading and running the Test Software (see “Loading and Running the Test Software” on page 23) and selecting the **Test Selections** field on the Lucent AMPS/TDMA Test Main Menu screen. The Test Software will display the Test Selections Menu screen (see Figure 4-2).

Once you have selected a test to run, see the following list to locate the description of that test.

- “Full Site Test (FCC)” on page 67.
- “Single Radio Test” on page 70.
- “TX Power Adjustment” on page 74.
- “Spectrum Analyzer” on page 77.
- “RX Gain Test” on page 82.
- “TX Gain Test” on page 80.
- “TX -39 dBm Power Test” on page 84.

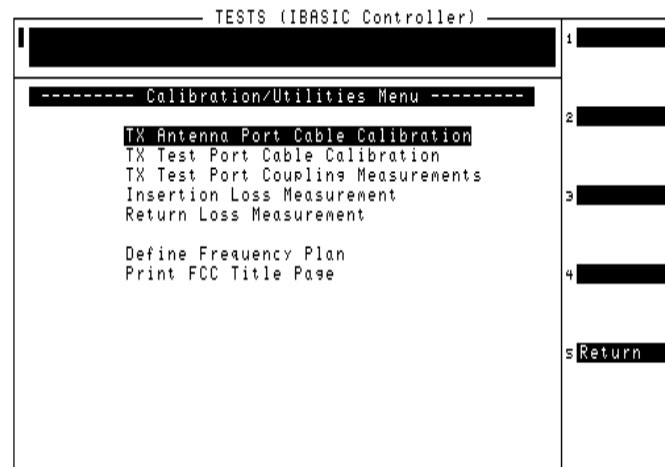
Figure 4-2 Test Selections Screen



Selecting Utilities

Select calibration and support utilities by loading and running the Test Software (see [“Loading and Running the Test Software”](#) on page 23) and selecting the **Calibration/Utilities** field on the Lucent AMPS/TDMA Test Main Menu screen. The Test Software will display the Calibration/Utilities Menu screen (see [Figure 4-3](#)).

Figure 4-3 Calibration/Utilities Menu Screen



Once you have selected a calibration procedure to run, see the following list to locate the description of that procedure.

- [“TX Antenna Port Cable Calibration”](#) on page 87.
- [“TX Test Port Cable Calibration”](#) on page 89.
- [“TX Test Port Coupling Measurements”](#) on page 91.
- [“Insertion Loss Measurement”](#) on page 94.
- [“Return Loss Measurement”](#) on page 96.

Once you have selected a support utility procedure to run, see the following list to locate the description of that procedure.

- [“Defining a Frequency Plan”](#) on page 45.
- [“Printing the FCC Title Page”](#) on page 43.

Running Tests

NOTE

Before starting to run operational tests, make certain that you have set PARAMETER 34. [ZZZZ Test Demo Mode \[0=normal 1=demo\]](#) to 0.

You are now ready to select and run tests. On the Test Selections Menu screen, scroll to the test that you wish to run, and press the knob to select it. The test will run. You may then select another test and run it in the same manner. You may repeat this operation as many times as is necessary.

After successfully running the tests, it is recommended that you save all of the configuration information as a procedure file on an SRAM card for later retrieval (see [“Saving/Deleting a Procedure” on page 113](#)). This eliminates the requirement for re-entering the information if you run a different program, change parameters when testing another Base Station, or install new operating system firmware in the Test Set.

For More Information

For more details on the tests in this chapter:

- [“Parameters” on page 122](#)
- [“Specifications \(Pass/Fail Limits\)” on page 129](#)

If there were problems or error messages were displayed when running a test:

See [Chapter 6, “Troubleshooting,” on page 135](#).

Full Site Test (FCC)

This test measures several aspects of radio performance on one radio or more. Measurements are made at the Base Station TX Test Ports in the Antenna Interface Frame, which eliminates the requirement to take an entire antenna face down during testing.

Before the test can run, you must to create a frequency plan containing information about each radio to be tested (see [“Defining a Frequency Plan” on page 45](#)). Because the Test Software uses the frequency plan to control automatically all of the radios under test, *this test cannot be performed using manual control of the Base Station*. If you must test a radio using manual control, use the [“Single Radio Test” on page 70](#).

Measurements

The measurements made on each radio depend on its type: AMPS, AMPS Setup, TDMA Voice, or TDMA with DCCH. The radio type is specified in the frequency plan.

AMPS and AMPS Setup Measurements

The following measurements are made on all radios:

- TX Frequency Error
- TX Power (at a specific power amplifier step)
- TX Peak (+) Data Deviation
- TX Peak (–) Data Deviation

The following additional measurements are only made on an AMPS radio (not AMPS Setup):

- TX RMS Residual FM
- TX Average Peak Deviation @ –16 dBm
- TX Distortion @ –16 dBm
- TX Peak (+) Deviation @ 0 dBm
- TX Peak (–) Deviation @ 0 dBm
- TX SAT Average Peak Deviation @ 5970 Hz, 6000 Hz, 6030 Hz
- TX SAT Frequency Error @ 5970 Hz, 6000 Hz, 6030 Hz

TDMA Measurements

The following measurements are made on TDMA radios:

- TX Power (at the specified VRAL setting)
- Frequency Error
- Origin Offset
- Error Vector Magnitude
- Lower Adjacent Channel Power
- Upper Adjacent Channel Power
- Lower First Alternate Channel Power
- Upper First Alternate Channel Power
- Lower Second Alternate Channel Power
- Upper Second Alternate Channel Power

After you have completed testing, if printing an FCC title page is appropriate, see [“Printing the FCC Title Page” on page 43](#).

Parameters and Specifications Used

The following parameters and specifications are used when running this test. See [Chapter 5, “Reference,” on page 99](#) for descriptions of the parameters and specifications.

Parameters:

- [1. Adjust TX Power \[0=no 1=on fail 2=always\]](#)
- [3. GN Power Output \[0=meas 1=spec 2=blnk\]](#)
- The TX Coupling factor for the associated antenna(s) listed in the frequency plan must be entered. This is done in parameters [24](#) through [30](#).
- [32. TX Test Port Cable Loss](#)

Specifications (Pass/Fail Limits):

This test uses all specifications described in [“Specifications \(Pass/Fail Limits\)” on page 129](#).

Select and Run the Test

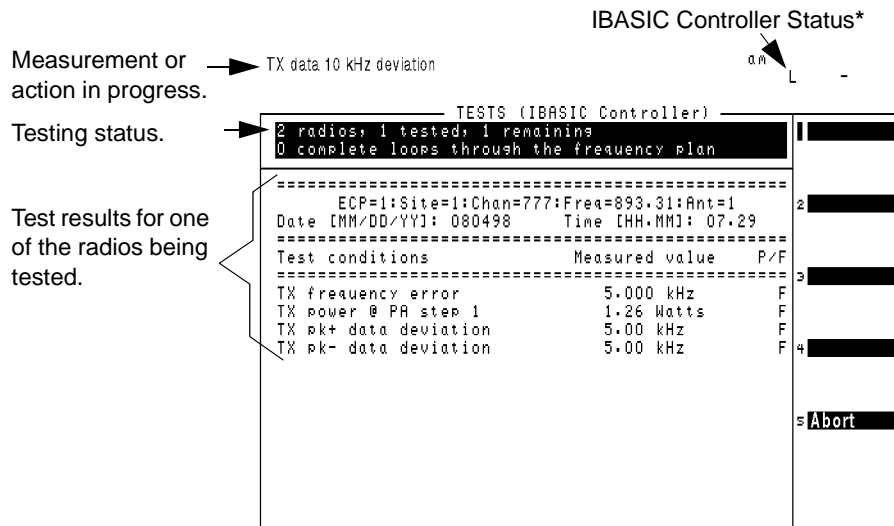
Select and run the Full Site Test (FCC) as follows:

- Step 1.** Create a frequency plan for the radios to be tested (see “Defining a Frequency Plan” on page 45).
- Step 2.** From the Lucent AMPS/TDMA Test Main Menu screen, select the **Test Selections** field. The Test Software will display the Test Selections Menu screen.
- Step 3.** Select the **Full Site Test (FCC)** field.
- Step 4.** Connect the Test Set to the Base Station as shown in the on-screen prompts.
- Step 5.** Press the **k1 [Proceed]** key.

Review the Results

The Test Software will display test results for each radio as it tests. It provides prompts at the top of the display to indicate the measurement or action currently being performed. See Figure 4-4.

Figure 4-4 Full Site Test Results for One AMPS Setup Radio



The IBASIC status indicators reflect the current state of the Test Set internal controller. An “L” means it is monitoring for a program command. A “T” means it is communicating with the Test Set or other connected HP-IB (HP Interface Bus: IEEE 488.2) device. A “C” means it is configured as the HP-IB controller to control external HP-IB devices. An asterisk () means the Test Software is running. A hyphen (-) means the Test Software is paused. An “R” means the Test Set is being controlled remotely (in this case, by a program working through the internal HP-IB).

Single Radio Test

This test measures several aspects of a single radio. When the test is run, a setup screen is displayed to specify information about the radio you want to test.

This test can be performed with the Base Station in service using the Base Station TX Test Port, or performed out-of-service using the Base Station TX Antenna Port (see “Which Test Set Port to Use – ANT IN or RF IN/OUT?” on page 36 and “Base Station Configuration” on page 41).

NOTE

If you elect to measure at that Base Station TX Antenna Port, in order to perform TDMA measurements on a digital control channel (DCCCH) radio, you must have set the **DCCCH Radio Equipped BTS** field to **YES**.

Measurements

The measurements made on each radio depends on its type: AMPS, AMPS Setup, or TDMA. The radio type is specified on the setup screen at the start of the test.

AMPS Radios

The following measurements are made on AMPS radios:

- TX Frequency Error
- TX Power (at a specific power amplifier step)
- TX RMS Residual FM
- TX Average Peak Deviation @ -16 dBm
- TX Distortion @ -16 dBm
- TX Peak (+) Deviation @ 0 dBm
- TX Peak (-) Deviation @ 0 dBm
- TX SAT Average Peak Deviation @ 5970 Hz
- TX SAT Frequency Error @ 5970 Hz
- TX SAT Average Peak Deviation @ 6000 Hz
- TX SAT Frequency Error @ 6000 Hz
- TX SAT Average Peak Deviation @ 6030 Hz
- TX SAT Frequency Error @ 6030 Hz
- TX Peak (+) Data Deviation
- TX Peak (-) Data Deviation

AMPS Setup Radios

The following measurements are made on AMPS Setup radios:

- SU TX Frequency Error
- SU TX Power (at a specific power amplifier step)
- SU Peak Data Deviation

TDMA Radios

The following measurements are made on TDMA radios:

- TX Power (at the specified VRAL setting)
- Frequency Error
- Origin Offset
- Error Vector Magnitude
- Lower Adjacent Channel Power
- Upper Adjacent Channel Power
- Lower First Alternate Channel Power
- Upper First Alternate Channel Power
- Lower Second Alternate Channel Power
- Upper Second Alternate Channel Power

Parameters and Specifications Used

The following parameters and specifications are used when running this test. See [Chapter 5, “Reference,” on page 99](#) for descriptions of the parameters and specifications.

Parameters:

- [1. Adjust TX Power \[0=no 1=on fail 2=always\]](#)
- [3. GN Power Output \[0=meas 1=spec 2=blnk\]](#)
- [21. TDMA DCCH Equipped \[0=No 1=Yes\]](#) - when measuring at the antenna foam jumper out of the Antenna Interface Frame.
- When measuring at the Base Station TX Test Port in the Antenna Interface Frame, the TX Coupling factor for the associated antenna must be entered. This is done in parameters [24](#) through [30](#).
- [31. TX Output Power](#)
- [32. TX Test Port Cable Loss](#) - when measuring at the Base Station TX Test Port in the Antenna Interface Frame.

Specifications (Pass/Fail Limits):

This test uses all specifications described in [“Specifications \(Pass/Fail Limits\)” on page 129](#).

Select and Run the Test

Select and run the Single Radio Test as follows:

Step 1. From the Lucent AMPS/TDMA Test Main Menu screen, select the **Test Selections** field. The Test Software will display the Test Selections Menu screen.

Step 2. Select the **Single Radio Test** field.

Step 3. Enter information about the radio in the Radio Test Menu screen.

For All Radio Types:

- Enter the **Specified Output Power** for the radio to be tested. This is the level that should be present at the output of the Antenna Interface Frame (that would normally connect to the transmit antenna feed line).
- Enter the **Cell Site Number** for the site.
- Enter the **Antenna Number** for the antenna connected to the radio.
- Select the **Radio Type** from the **Choices:** list: AMPS, AMPS Setup, TDMA Voice, or TDMA with DCCH.

For AMPS or TDMA Radios:

- Enter the **Channel Number** for the radio under test.
- Enter the **Radio ID#** (number) for the radio under test.
- Enter the VRAL (Voice RAdio Level) for the radio under test.
- Set the **Send Commands to MSC** field to **YES** for automated testing using a PC, or **NO** to control the Base Station using another method.

For AMPS Setup Radios:

- Set the **Configuration Status** to **Active** to test a radio while it is in service, or select **Configured** to take the radio out of service for testing.
- Enter the **Channel Number** for the setup radio under test.
- Enter the **Setup ID#** (number) for the setup radio under test.
- Enter the **CSAC** (Control Setup Attenuation Code) for the setup radio under test.
- Set the **Send Commands to MSC** field to **YES** for automated testing using a PC, or **NO** to control the Base Station using another method.

Step 4. Press the **k1 [Run]** key to begin the test.

Step 5. Follow the on-screen prompts and setup diagram to complete the testing.

Review the Results

The Test Software will display test results for the radio as it tests. It provides prompts at the top of the display to indicate the measurement or action currently being performed. See [Figure 4-5](#).

Figure 4-5 Partial Single Radio Test Results for AMPS Radio

Measurement or action in progress. → TX SAT frequency error

TESTS (IBASIC Controller)		
ECP=1:Site=1:Chan=777:Frea=893.31:Ant=1		
Date [MM/DD/YY]: 080498	Time [HH.MM]: 09.37	
=====		
Test conditions	Measured value	P/F
=====		
TX frequency error	5.000 kHz	F 3
TX power @ PA step 0	1.26 Watts	F
TX rms residual FM	5.00 Hz	F
TX avg pk dev @ -16 dBm	5.00 kHz	F
TX distortion @ -16 dBm	5.00 %	F
TX pk+ dev @ 0 dBm	5.00 kHz	F
TX pk- dev @ 0 dBm	5.00 kHz	F
TX SAT avg pk dev @ 5970 Hz	5.00 kHz	F
TX SAT freq err @ 5970 Hz	-5965.00 Hz	F 5 Abort
TX SAT avg pk dev @ 6000 Hz	5.00 kHz	F
TX SAT freq err @ 6000 Hz	-5995.00 Hz	F
TX SAT avg pk dev @ 6030 Hz	5.00 kHz	F

TX Power Adjustment

This adjustment procedure provides an analog display of power measurements. This mode is useful when making adjustments to power levels on a transmitter.

Features of the power meter display include:

- Tick marks on the meter to indicate when a power level setting is within limits.
- Audible tones to indicate whether the power reading falls within limits.
- A USER key to choose between measurement units of dBm or Watts.

This test may be performed with the Base Station in service using the Base Station TX Test Port, or out-of-service using the Base Station TX Antenna Port (see [“Which Base Station Port to Use – TX Test or TX Antenna?”](#) on page 36 and [“Base Station Configuration”](#) on page 41.

Parameters and Specifications Used

The following parameters and specifications are used when running this test. See [Chapter 5, “Reference,”](#) on page 99 for descriptions of the parameters and specifications.

Parameters:

- [21. TDMA DCCH Equipped \[0=No 1=Yes\]](#) - when measuring at the antenna foam jumper out of the Antenna Interface Frame.
- When measuring at the Base Station TX Test Port in the Antenna Interface Frame, the TX Coupling factor for the associated antenna must be entered. This is done in parameters [24](#) through [30](#).
- [32. TX Test Port Cable Loss](#) - when measuring at the Base Station TX Test Port in the Antenna Interface Frame.

Specifications (Pass/Fail Limits):

- [9. Output Power Adjustment Error](#). The upper and lower limits are indicated by the longer tick marks on the power meter display.

Select and Run the Test

Select and run the TX Power Adjustment as follows:

- Step 1.** From the Lucent AMPS/TDMA Test Main Menu screen, select the **Test Selections** field. The Test Software will display the Test Selections Menu screen.
- Step 2.** Select the **TX Power Adjustment** field. The Test Software will display the TX Power Adjustment screen.

Step 3. Enter information about the radio on the TX Power Adjustment screen.

For All Radio Types:

- Enter the **Specified Output Power** for the radio to be tested. This is the level that should be present at the output of the Antenna Interface Frame (that would normally connect to the transmit antenna feed line).
- Enter the **Cell Site Number** for the site at which testing is being performed.
- Enter the **Antenna Number** for the antenna connected to the radio to be tested.
- Select the **Radio Type** from the **Choices:** list: AMPS, AMPS Setup, TDMA Voice, or TDMA with DCCH.

For AMPS or TDMA Radios:

- Enter the **Channel Number** for the radio to be tested.
- Enter the **Radio ID#** (number) for the radio to be tested.
- Enter the VRAL (Voice RAdio Level) for the radio to be tested.
- Set the **Send Commands to MSC** field to **YES** for automated testing using a modem, or **NO** to control the Base Station using another method.

For AMPS Setup Radios:

- Set the **Configuration Status** to **Active** to test a radio while it is in service, or select **Configured** to take the radio out of service for testing.
- Enter the **Channel Number** for the setup radio to be tested.
- Enter the **Setup ID#** (number) for the setup radio to be tested.
- Enter the **CSAC** (Control Setup Attenuation Code) for the setup radio to be tested.
- Set the **Send Commands to MSC** field to **YES** for automated testing using a modem, or **NO** to control the Base Station using another method.

Step 4. Press the **k1 [Run]** key to begin the test.

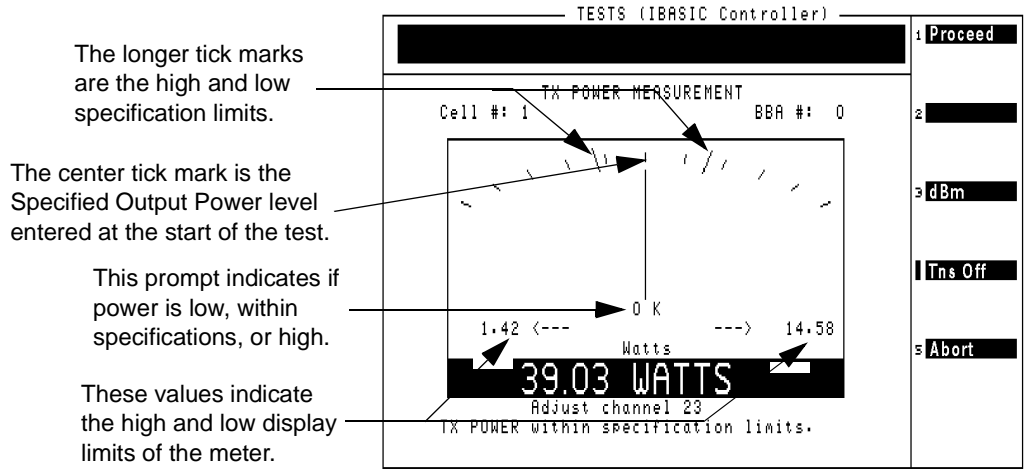
Step 5. Follow the on-screen prompts and setup diagram to complete the testing.

Review the Results

The Test Software will display the power meter screen (see [Figure 4-6](#)).

The power meter display defaults to units of Watts. To view the power level in dBm, press the **k3 (dBm)** key. A beeping tone accompanies the measurement to assist in adjusting the transmitter power without watching the display. Adjust the tone volume by pressing the **k4 (Tns off, Tns quiet, Tns loud)** key.

Figure 4-6 Power Meter Display



Spectrum Analyzer

This function configures the Test Set to display spectrum sweeps. It is useful in verifying the presence of a signal or searching for interference sources.

This function may be performed in-service or out-of-service. See [“Which Base Station Port to Use – TX Test or TX Antenna?”](#) on page 36.

Parameters and Specifications Used

The following parameters and specifications are used when running this test. See [Chapter 5, “Reference,”](#) on page 99 for descriptions of the parameters and specifications.

Parameters:

- [21. TDMA DCCH Equipped \[0=No 1=Yes\]](#) - when measuring at the antenna foam jumper out of the Antenna Interface Frame.
- When measuring at the Base Station TX Test Port in the Antenna Interface Frame, the TX Coupling factor for the associated antenna must be entered. This is done in parameters [24](#) through [30](#).
- [32. TX Test Port Cable Loss](#) - when measuring at the Base Station TX Test Port in the Antenna Interface Frame.

Specifications (Pass/Fail Limits):

- None used for this test.

Select and Run the Test

Select and run the Spectrum Analyzer test as follows:

- Step 1.** From the Lucent AMPS/TDMA Test Main Menu screen, select the **Test Selections** field. The Test Software will display the Test Selections Menu screen.
- Step 2.** Select the **Spectrum Analyzer** field.
- Step 3.** Enter information about the radio in the Spectrum Analyzer menu.

For All Radio Types:

- Enter the **Specified Output Power** for the radio to be tested. This is the level that should be present at the output of the Antenna Interface Frame (that would normally connect to the transmit antenna feed line).
- Enter the **Cell Site Number** for the site.
- Enter the **Antenna Number** for the antenna connected to the radio.
- Select the **Radio Type** from the **Choices:** list: AMPS, AMPS Setup, TDMA Voice, or TDMA with DCCH.

For AMPS or TDMA Radios:

- Enter the **Channel Number** for the radio.
- Enter the **Radio ID#** (number) for the radio.
- Enter the **VRAL** (Voice RAdio Level) for the radio.
- Set the **Send Commands to MSC** field to **YES** for automated testing using a modem, or **NO** to control the Base Station using another method.

For AMPS Setup Radios:

- Set the **Configuration Status** to **Active** to test a radio while it is in service, or select **Configured** to take the radio out of service for testing.
- Enter the **Channel Number** for the setup radio.
- Enter the **Setup ID#** (number) for the setup radio.
- Enter the **CSAC** (Control Setup Attenuation Code) for the setup radio.
- Set the **Send Commands to MSC** field to **YES** for automated testing using a modem, or **NO** to control the Base Station using another method.

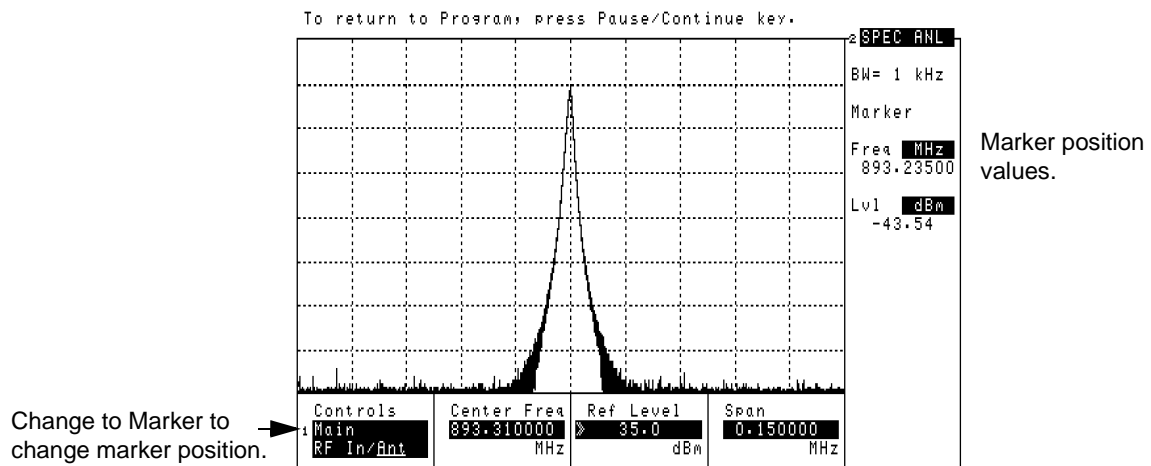
Step 4. Press the **k1 [Run]** key to begin the test.

Step 5. Follow the on-screen prompts and setup diagram to view the signal on the spectrum analyzer.

Review the Results

The Test Software will set up and display the spectrum analyzer. See [Figure 4-7](#).

Figure 4-7 Spectrum Analyzer Display



Use the **Ref Level** and **Span** fields for the best view of the transmitted signal.

Read the marker frequency and level in the upper-right of the display. To change the marker position, use the **Controls** field to select **Marker**, then use the **Position** field.

NOTE

Do not make changes to the **Center Freq** field.

If you would like to view another channel/frequency, return to the Lucent AMPS/TDMA Test Main Menu screen and select **Test Configuration** (to access the Test Configuration Menu screen) and change the **Channel Number**, then re-run the test.

When you have finished using the spectrum analyzer, press the **Pause/Continue** key. The Test Software will return to the Test Selections Menu screen.

TX Gain Test

This test measures the gain of a low-output-power element.

CAUTION

This test is designed to measure the gain through **only** low-output-power elements. It is not designed to measure the LAC gain on a Series II Base Station or power amplifiers on the other Base Stations.

On PCS Minicell Base Stations, this test is used to measure the transmit gain through the TDMA Transmit Unit (TTU). Because the TTU translates the 850-MHz frequency from TDMA radios in the Minicell to a 1900-MHz output frequency, the Test Software will offset the Test Set frequencies appropriately to test the gain through the TTU. This requires that the sector being tested be taken out of service because the cables to and from the TTU must be disconnected.

On 850-MHz Base Stations, this test is used to measure the transmit gain through low-power TX devices in the Base Station.

CAUTION

This test uses the Test Set ANT IN port to measure the output level of the TTU. Input levels to this port greater than 60 milliwatts (17.8 dBm) might damage the Test Set. Therefore, the power output of the unit under test must not exceed 60 milliwatts.

Parameters and Specifications Used

The following parameters and specifications are used when running this test. See [Chapter 5, "Reference," on page 99](#) for descriptions of the parameters and specifications.

Parameters:

- 17. MSC BTS Type [1=Series II 2=M 3=MM 4=PCS]

Specifications (Pass/Fail Limits):

None used for this test.

Select and Run the Test

Select and run the TX Gain Test as follows:

- Step 1.** Take the affected radios and the amplifier to be tested out of service. Use a PC to dial into the MSC and enter the craft shell, or call the MSC and instruct switch personnel as to which radio to turn off.
- Step 2.** From the Lucent AMPS/TDMA Test Main Menu screen, select the **Test Selections** field. The Test Software will display the Test Selections Menu screen.
- Step 3.** Select the **TX Gain Test** field. The Test Software will display the TX Gain Test screen.

Step 4. Select the **Channel Number** field. Enter the channel number of the radio by either turning the knob to the desired number and pressing it, or using the DATA ENTRY keys to enter the number, then either pressing the knob or the **Enter** key to select it.

NOTE

The number that you enter in the **Channel Number** field represents the output frequency of the device to be tested.

In the case of a PCS Minicell, you must enter a channel number that sets the input frequency of the TTU to the proper 850-MHz-band frequency to obtain the desired 1900-MHz-band output frequency from the translator.

In the case of an 850-MHz Base Station, the input and output frequencies will be the same.

Step 5. Select the **Generator Output Level [dBm]** field. Enter the signal level from the Test Set into the amplifier by either turning the knob to the desired value and pressing it, or using the DATA ENTRY keys to enter the value, then either pressing the knob or the **Enter** key to select it.

CAUTION

Make certain to enter a level in the **Generator Output Level [dBm]** field that will not produce an output level greater than 60 milliwatts from the unit being tested. Input levels to the ANT IN port greater than 60 milliwatts might damage the Test Set.

Step 6. Press the **k1 (Run)** key. The Test Software display a connection diagram.

Step 7. Connect two cables as shown in the connection diagram.

Step 8. Press the **k1 (Proceed)** key. The Test Software will measure the losses through the test cables, then display a query asking if any transmitters are active in the amplifier path.

If any transmitter is active and you do not wish to continue the test at this time, press the **k1 (Yes)** key. The Test Software will discontinue the test and return to the TX Gain Test screen.

If no transmitter is active, press the **k2 (No)** key to continue the test. The Test Software will display a connection diagram.

Step 9. Connect the amplifier to be tested as shown in the second connection diagram.

Step 10. Press the **k1 (Proceed)** key to perform the measurement.

Review the Results

The Test Software will display the gain and re-measure it continuously to allow for real time adjustment.

Press the **k1 (Proceed)** key to return to the TX Gain Test screen.

RX Gain Test

This test measures the gain of a Base Station Receive Unit (RU).

CAUTION

This test is designed to measure the gain through **only** low-output-power elements.

On PCS Minicell Base Stations, this test is used to measure the receive gain through the RU. Because the TTU translates the 1900-MHz input frequency down to the 850-MHz frequency of the TDMA radio, the Test Software will offset the Test Set frequencies appropriately to test the gain through the RU. This requires that the sector being tested be taken out of service because the cables to and from the RU must be disconnected.

On 850-MHz Base Stations, this test is used to measure the gain through RX devices such as low-noise amplifiers in the Base Station.

CAUTION

This test uses the Test Set ANT IN port to measure the output level of the TTU. Input levels to this port greater than 60 milliwatts (17.8 dBm) might damage the Test Set. Therefore, the power output of the unit under test must not exceed 60 milliwatts.

Parameters and Specifications Used

The following parameters and specifications are used when running this test. See [Chapter 5, "Reference," on page 99](#) for descriptions of the parameters and specifications.

Parameters:

- 17. MSC BTS Type [1=Series II 2=M 3=MM 4=PCS]

Specifications (Pass/Fail Limits):

None used for this test.

Select and Run the Test

Select and run the RX Gain Test as follows:

- Step 1.** Take the affected radios and the amplifier to be tested out of service. Use a PC to dial into the MSC and enter the craft shell, or call the MSC and instruct switch personnel as to which radio to turn off.
- Step 2.** From the Lucent AMPS/TDMA Test Main Menu screen, select the **Test Selections** field. The Test Software will display the Test Selections Menu screen.
- Step 3.** Select the **RX Gain Test** field. The Test Software will display the RX Gain Test screen.

Step 4. Select the **Channel Number** field. Enter the channel number of the radio by either turning the knob to the desired number and pressing it, or using the DATA ENTRY keys to enter the number, then either pressing the knob or the **Enter** key to select it.

NOTE

The number that you enter in the **Channel Number** field represents the output frequency of the device to be tested.

In the case of a PCS Minicell, you must enter a channel number that sets the input frequency of the RU to the proper 1900-MHz-band frequency to obtain the desired 850-MHz-band output frequency from the translator.

In the case of an 850-MHz Base Station, the input and output frequencies will be the same.

Step 5. Select the **Generator Output Level [dBm]** field. Enter the signal level from the Test Set into the amplifier by either turning the knob to the desired value and pressing it, or using the DATA ENTRY keys to enter the value, then either pressing the knob or the **Enter** key to select it.

CAUTION

Make certain to enter a level in the **Generator Output Level [dBm]** field that will not produce an output level greater than 60 milliwatts from the unit being tested. Input levels to the ANT IN port greater than 60 milliwatts might damage the Test Set.

Step 6. Press the **k1 (Run)** key. The Test Software will display a connection diagram.

Step 7. Connect two cables as shown in the connection diagram.

Step 8. Press the **k1 (Proceed)** key. The Test Software will measure the losses through the test cables, then display a second connection diagram.

Step 9. Connect the amplifier to be tested as shown in the second connection diagram.

Step 10. Press the **k1 (Proceed)** key to perform the measurement.

Review the Results

The Test Software will display the gain and re-measure it continuously to allow for real time adjustment.

Press the **k1 (Proceed)** key to return to the RX Gain Test screen.

TX -39 dBm Power Test

This test provides the process by which all radios are adjusted to produce drive signals to the linear amplifier circuit (LAC) that are approximately equal and within the proper range. This test uses information from the frequency table to determine which radios are applicable for the test.

If you select a reference radio, the basic procedure performed in this test is as follows:

- Select one reference radio for each equipped antenna per LAC. If possible, select the farthest right-hand voice radio (not setup radio) in shelf 2, 3, or 4 of the primary radio channel frame (PRCF). If there is an antenna in the PRCF that does not have an associated transmitting radio, select the farthest right-hand radio in shelf 2, 3, or 4 of the growth radio channel frame (GRCF) as the reference radio for that antenna.
- Connect a test cable of known loss to the Test Set ANT IN port. Connect the other end of the test cable to the Base Station TX SIG MON jack corresponding to the first reference radio.
- The command *config multi radio* is issued to the Base Station to turn on all radio transmitters.
- Turn off all radios by switching the AUTO/OFF switch to OFF.
- Turn on the reference radio by switching the AUTO/OFF switch to AUTO. Adjust the potentiometer on the reference radio front panel for a -39 dBm TX SIG MON output. Once power is set, turn off the reference radio by setting the AUTO/OFF switch to OFF. Disconnect the Test Set from the SIG MON jack.
- Remove the Test cable. Connect a test cable between the Base Station Antenna Output and the Test Set RF IN/OUT port.
- Turn on the reference radio. Adjust the LAC preamplifier for maximum power, for minimum power, and finally to the desired power as defined in the frequency plan for the reference radio. Turn off the reference radio.
- The next series of steps is to turn on the radios, one at a time, set the power of each radio using the potentiometer on the radio front panel, and then turn off the radio. The power is determined by the power setting defined for that radio in the frequency plan.
- Once the power has been set on all radios, the restore commands are issued to the radios to turn off all transmitters.
- Disconnect the cable between the Base Station Antenna Output and the Test Set. Reconnect the Base Station Antenna Output to the foam jumper.

Parameters and Specifications Used

The following parameters and specifications are used when running this test. See [Chapter 5, “Reference,” on page 99](#) for descriptions of the parameters and specifications.

Parameters:

- [3. GN Power Output \[0=meas 1=spec 2=blnk\]](#)
- [22. TDMA Number of Averages for Readings](#)
- [23. TX Antenna Port Cable Loss](#)
- [32. TX Test Port Cable Loss](#)

Specifications (Pass/Fail Limits):

- [10. Output Power Error](#)

Select and Run the Test

Select and run the TX -39 dBm Power Test as follows:

- Step 1.** Take the selected antenna face, out of service. (Use the PC to dial into the MSC and enter the craft shell, or call the MSC and instruct switch personnel as to which radio to turn off.)
- Step 2.** Enter a frequency plan (see [“Defining a Frequency Plan” on page 45](#)).
- Step 3.** From the Lucent AMPS/TDMA Test Main Menu screen, select the **Test Selections** field. The Test Software will display the Test Selections Menu screen.
- Step 4.** Select the **TX -39 dBm Power Test** field. The Test Software will display the TX -39 dBm Power Test Menu screen.
- Step 5.** Select the **Antenna Number** field. Enter the antenna number by either turning the knob to the desired number and pressing it, or using the DATA ENTRY keys to enter the number, then either pressing the knob or the **Enter** key to select it.
- Step 6.** Scroll to the **Adjust Radio Power** field and press the knob to toggle it to the desired mode.

If you select **Always**, the radio power will be adjusted in every instance.

If you select **On Failure**, the radio power will be adjusted only on failure.

- Step 7.** Scroll to the **Use Reference Radio** field and press the knob to toggle it to the desired mode.

If you select **YES**, the Test Software will lead you through a step-by-step process that uses one radio in the face to set a -39 dBm reference level at the TX SIG MON jack. The reference level becomes a known good drive level input to the LAC preamplifier. This allows the LAC preamplifier to be adjusted properly for the desired output level. Once the LAC preamplifier is adjusted properly, all other radios may be adjusted by simply setting the potentiometer on each radio front panel.

Also, if you select **Yes**, the **Do you need assistance?** field will appear immediately below. Press the knob to toggle the field to the desired setting. If you understand the testing process and wish to have the Test Software perform it as automatically as possible, select **No**. If you wish to have the Test Software display informational screens at appropriate points in the testing process to assist you in performing the operations, select **Yes**.

If you select **NO**, the Test Software will assume that the LAC preamplifier is adjusted properly for the power level for the face and the power output for each radio defined in the frequency plan, as measured at the Base Station RF Antenna Port, by adjusting the potentiometer on the radio front panel.

Step 8. Scroll to the **Send Commands to MSC** field and press the knob to toggle it to the desired mode.

Select **YES** for automated testing using a PC for control.

Select **NO** to control the Base Station using another method.

Step 9. Press the **k1 (Proceed)** key. The Test Software will display prompts to guide you through a step-by-step process for adjusting the power of each radio in the face. If you selected a reference radio, the Test Software will also guide you through the process of setting the reference radio. During the process, the Test Software will display prompts directing you to make connections, make inputs to the Test Software, turn radios on and off, and make power adjustments.

Review the Results

At appropriate points in the test, the Test Software will display the measurement results.

Press the **k1 (Proceed)** key when the test is completed to return to the TX -39 dBm Power Test Menu screen.

TX Antenna Port Cable Calibration

This calibration utility measures the signal loss through the cable used to connect the Test Set to the Base Station TX antenna Port. (This loss must be known when making power measurements at this port. Once you have measured this value, label the cable indicating the loss for future use.) This utility sends no control commands to the MSC.

After measuring the cable loss, the Test Software will display the loss value and the frequency used for the test, then display a query asking if you wish to store the value.

- If you select **Yes**, the Test Software will enter the value automatically in the Base Station Configuration Menu. Unless you believe that the indicated loss is incorrect, you should select Yes.
- If you select **No**, the Test Software will display a query asking if you wish to **Remeasure** the loss or **Return** to the Calibration/Utilities Menu.

This routine requires the use of two external 6-dB attenuators (pads) and a short calibration cable. These parts are not standard equipment with the Test Set, but are included in the optional connector kit (see [“Optional Accessory Kits” on page 17](#)).

Parameters and Specifications Used

The following parameters and specifications are used when running this test. See [Chapter 5, “Reference,” on page 99](#) for descriptions of the parameters and specifications.

Parameters:

- [21. TDMA DCCH Equipped \[0=No 1=Yes\]](#)

Specifications (Pass/Fail Limits):

None used for this test.

Select and Run the Utility

Select and run the TX Antenna Port Cable Calibration utility as follows:

- Step 1.** From the Lucent AMPS/TDMA Test Main Menu screen, select the **Calibration/Utilities** field. The Test Software will display the Calibration/Utilities Menu screen.
- Step 2.** Select the **TX Antenna Port Cable Calibration** field.
- Step 3.** Follow the on-screen prompts to connect the 6-dB pads and calibration cable, then press the **k1 (Proceed)** key.
- Step 4.** Follow the on-screen prompts to connect the test cable in series with the calibration cable and pads, then press the **k1 (Proceed)** key.

Review the Results

The Test Software will display the measured insertion loss and test frequency. When you press the **k1 (Proceed)** to continue, the Test Software will display a query asking if you wish to store the insertion loss as the TX Antenna Port Cable Loss. Turn and press the knob to select **Yes** or **No**.

TX Test Port Cable Calibration

This calibration utility measures the signal loss through the cable used to connect the Test Set to the Base Station TX Test Port. This is the Base Station port that samples the transmitter output through a directional coupler in the Antenna Interface Frame. (This loss must be known when making power measurements at this port. Once you have measured this value, label the cable indicating the loss for future use.) This utility sends no control commands to the MSC.

After measuring the cable loss, the Test Software will display the loss value and the frequency used for the test, then display a query asking if you wish to store the value.

- If you select **Yes**, the Test Software will enter the value automatically in the Base Station Configuration Menu. Unless you believe that the indicated loss is incorrect, you should select Yes.
- If you select **No**, the Test Software will display a query asking if you wish to **Remeasure** the loss or **Return** to the Calibration/Utilities Menu.

This routine requires the use of two external 6-dB attenuators (pads) and a short calibration cable. These parts are not standard equipment with the Test Set, but are included in the optional connector kit (see [“Optional Accessory Kits” on page 17](#)).

Parameters and Specifications Used

The following parameters and specifications are used when running this test. See [Chapter 5, “Reference,” on page 99](#) for descriptions of the parameters and specifications.

Parameters:

- [32. TX Test Port Cable Loss](#)

Specifications (Pass/Fail Limits):

None used for this test.

Select and Run the Utility

Select and run the TX Test Port Cable Calibration utility as follows:

- Step 1.** From the Lucent AMPS/TDMA Test Main Menu screen, select the **Calibration/Utilities** field. The Test Software will display the Calibration/Utilities Menu screen.
- Step 2.** Select the **TX Test Port Cable Calibration** field.
- Step 3.** Follow the on-screen prompts to connect the 6 dB pads and calibration cable.
- Step 4.** Press the **k1 (Proceed)** key to continue.
- Step 5.** Follow the on-screen prompts to connect the test cable in series with the calibration cable and pads.
- Step 6.** Press the **k1 (Proceed)** key to continue.

Review the Results

The Test Software will display the measured insertion loss and test frequency. When you press the **k1 (Proceed)** to continue, the Test Software will display a query asking if you wish to store the insertion loss as the TX Test Port Cable Loss. Turn and press the knob to select **Yes** or **No**.

TX Test Port Coupling Measurements

This utility measures the loss associated with testing from a Base Station TX Test Port. This provides to the Test Software a coupling factor to use with measurements from that TX Test Port. Repeat this measurement for each test port to be used at the cell site.

At the start of the test, you must select full or partial calibration.

- In **Full** calibration, the Test Software will first measure the level at the Base Station TX Antenna Port, then the level at the Base Station TX Test Port. It will then use the difference between these levels to determine the loss through the TX Test Port.

If you have connected and configured a PC for automated control of the Base Station, the Test Software will send commands to the MSC during the test. If you wish to use manual Base Station control, you must disable call processing and turn off any transmitters prior to connecting the Test Set to the Base Station TX Antenna Port.

NOTE

During full calibration, the Test Software will prompt you to connect the Test Set RF IN/OUT port to the Base Station TX Antenna Port using the TX Antenna Port cable. After you have done so, the Test Software will prompt you to connect the Test Set ANT IN port to the Base Station TX Test Port using the TX Test Port cable.

For accurate TX Test port calibration, you must use the correct cables when prompted.

- In **Partial** calibration, the Test Software will use the Reference Power Level that you enter in the **Specified Output Power** field of the Base Station Configuration Menu screen to determine the coupling factor. (This is the level out of the Antenna Interface Frame that feeds the foam jumper to the transmit antenna.) The Test Software then measures the level at the Base Station TX Test Port and uses the difference in these levels is used to determine the loss through the TX Test port.

Unless you are certain that the Reference Power Level that you enter is correct (± 0.5 dB), you should use the full calibration for the most accurate results.

Parameters and Specifications Used

The following parameters and specifications are used when running this test. See [Chapter 5, "Reference," on page 99](#) for descriptions of the parameters and specifications.

Parameters:

- [21. TDMA DCCH Equipped \[0=No 1=Yes\]](#)
- [32. TX Test Port Cable Loss](#)

Specifications (Pass/Fail Limits):

- None used for this test.

Select and Run the Test

Select and run the TX Test Port Calibration utility as follows:

NOTE

This procedure might include prompts requiring that you disconnect cables from the Test Set antenna port and RF IN/OUT port. Before removing or re-installing the antenna cables, make certain that the transmitter has been turned off by the MSC (or by switch personnel if not using a PC).

- Step 1.** From the Lucent AMPS/TDMA Test Main Menu screen, select the **Calibration/Utilities** field. The Test Software will display the Calibration/Utilities Menu screen.
- Step 2.** Select the **TX Test Port Coupling Measurements** field. The Test Software will display the TX Coupling Measurements screen.
- Step 3.** Select the **Radio Type** from the **Choices:** list: AMPS, AMPS Setup, TDMA Voice, or TDMA with DCCH.

For AMPS or TDMA Radios:

- Enter the **Channel Number** for the radio to be tested at the port.
- Enter the **Antenna Number** for the Base Station TX Test Port.
- Enter the **Measurement Type**, either **Full** or **Partial**.
- If you selected **Partial** in the step above, enter the **Reference Power Level** that should be present at the Base Station TX Antenna Port.
- Set the **Send Commands to MSC** field to **YES** for automated testing using a PC, or **NO** to control the Base Station using another method.

If you selected **Yes**, enter the **Radio ID#** (number).

If you selected **Yes**, enter the **VRAL** (Voice RAdio Level) for the radio.

If you selected **No**, the Test Software will prompt you to take each radio for the selected antenna out of service and turn it on and off as required during the tests.

For AMPS Setup Radios:

- Enter the **Channel Number** for the radio to be tested at the port.
- Enter the **Antenna Number** for the Base Station TX Test Port.
- Enter the **Measurement Type**, either **Full** or **Partial**.
- If you selected **Partial** in the step above, enter the **Reference Power Level** that should be present at the Base Station TX Antenna Port.
- Set the **Send Commands to MSC** field to **YES** for automated testing using a PC, or **NO** to control the Base Station using another method.

If you selected **Yes**, enter the **Radio ID#** (number).

If you selected **Yes**, enter the **CSAC** (Control Setup Attenuation Code) for the radio.

If you selected **No**, the Test Software will prompt you to take each radio for the selected antenna out of service and turn it on and off as required during the tests.

Step 4. Press the **k1 (Run)** key.

Step 5. Connect the Test Set to the Base Station as indicated and perform any other operations as prompted. Press the **k1 (Proceed)** key to continue after each setup.

- Full calibration requires two separate measurement setups. Make certain to use the correct test cables for each setup.
- Partial calibration uses one measurement setup. Make certain to use the TX Test Port cable when making the measurement.

Review the Results

The Test Software will calculate and display the Base Station TX Test Port coupling factor. You should write this value next to the TX Test Port for future reference.

Press the **k1 (Proceed)** key to return to the Calibration/Utilities Menu screen, then press the **k5 (Return)** key to return to the Lucent AMPS/TDMA Test Main Menu screen.

If you then select the **Base Station Configuration** field (from the Lucent AMPS/TDMA Test Main Menu screen), you will note that the **TX Test Port Coupling Factor [dB]** field for the specified antenna now contains the value determined by the test.

Insertion Loss Measurement

This utility measures the loss associated with RF cables, filters, and other passive devices in the measurement path. This test uses the Test Set internal source and measures the relative loss through the cable or device. This utility sends no control commands to the MSC.

To optimize measurement accuracy, the measurement setup uses two external 6-dB attenuators (pads) and a short calibration cable. The pads are optional, but should be used if available. These parts are not standard equipment with the Test Set, but are included in the optional accessory kit (see “[Optional Accessory Kits](#)” on page 17).

Parameters and Specifications Used

The following parameters and specifications are used when running this test. See [Chapter 5, “Reference,”](#) on page 99 for descriptions of the parameters and specifications.

Parameters:

- None used for this test.

Specifications (Pass/Fail Limits):

- None used for this test.

Select and Run the Test

Select and run the Insertion Loss Measurement as follows:

- Step 1.** From the Lucent AMPS/TDMA Test Main Menu screen, select the **Calibration/Utilities** field. The Test Software will display the Calibration/Utilities Menu screen.
- Step 2.** Select the **Insertion Loss Measurement** field.
- Step 3.** If the Test Software determines that channel power must be calibrated before testing, it will display a prompt directing you to disconnect all cables from the Test Set. Disconnect any cables, and press the **k1 (Proceed)** key.
- Step 4.** Scroll to the **Loss Measurement Type** field and press the knob to toggle the setting to **Swept** or **Discrete**.

If you select **swept**, the Test Software will measure the loss over the frequency range that you specify. The following four fields will appear below. In each instance, either enter the number by turning the knob to the desired value and pressing it, or enter the number using the DATA ENTRY keys, then either press the knob or the **Enter** key to select it.

- **Start Frequency [MHz]** – Enter the start frequency.
- **Stop Frequency [MHz]** – Enter the stop frequency.

- **Maximum Expected Loss [dB]** – Enter the loss for the device being tested. The Test Software will use this value to adjust the scale on the results plot. Use a value slightly greater than expected for the best display resolution.
- **Duplex Out Level [dBm]** – Enter the setting for the appropriate level into the device being tested. This may be adjusted if necessary.

If you select **Discrete**, the Test Software will measure the loss at the frequency that you specify by entering the **Channel Number** to be tested. The **Channel Number** field will appear below. Enter the number by turning the knob to the desired value and pressing the knob, or use the DATA ENTRY keys to enter the number and then either press the knob or the **Enter** key to select it.

Step 5. Press the **k1 (Run)** key.

Step 6. Follow the on-screen prompts to connect the 6-dB pads and calibration cable.

Step 7. Press the **k1(Proceed)** key.

Step 8. Follow the on-screen prompts to connect the test cable, or other RF device, in series with the calibration cable and pads.

Step 9. Press the **k1(Proceed)** key to perform the measurement.

Review the Results

If you have selected a discrete measurement, the Test Software will display the insertion loss as a single numeric value (in units of dB).

If you have selected a swept measurement, the Test Software will display the loss as a spectrum analyzer plot of loss versus frequency.

If you wish to record the spectrum analyzer plot of the results of a swept measurement, press the **k5 (Scr Dump)** key. This will cause the Test Software to pause automated operation to print a summary of the plot. Press the **Print** key to send the plot to a PC connected to the Test Set. After the summary has printed in the BTS Laptop Utility program **Test Set Screen Capture** window, press the **k2 (Continue)** key to re-start the Test Software at the point at which it paused. You may save the window contents to a file in the PC.

Press the **k1 (Proceed)** key to display the frequency range settings and average insertion loss for the test. From this point, you may press the **k1 (Repeat)** key to test another cable or device, press the **k5 (Return)** key once to return to the Insertion Loss Test setup menu, or press the **k5 (Return)** key twice to return to the Calibration/Utilities Menu.

Return Loss Measurement

This utility measures the return loss of a cable, antenna, or other device in the swept mode. An SWR bridge and a 6-dB pad are connected to the Test Set. The Test Software uses the pad to improve the mismatch between the SWR bridge and the ANT IN port on the Test Set. It measures a reference level with an open or short on the bridge, measures the return loss with the cable or antenna-under-test, and displays the results. This utility sends no control commands to the MSC.

This measurement requires the use of two external 6-dB attenuators (pads), two type-N cables, and an SWR bridge. These parts are not standard equipment with the Test Set, but are included in the optional accessory kit (see [“Optional Accessory Kits” on page 17](#)).

Parameters and Specifications Used

The following parameters and specifications are used when running this test. See [Chapter 5, “Reference,” on page 99](#) for descriptions of the parameters and specifications.

Parameters:

- None used for this test.

Specifications (Pass/Fail Limits):

- None used for this test.

Select and Run the Test

Select and run the Return Loss Measurement as follows:

- Step 1.** From the Lucent AMPS/TDMA Test Main Menu screen, select the **Calibration/Utilities** field. The Test Software will display the Calibration/Utilities Menu screen.
- Step 2.** Scroll to **Return Loss Measurement** and press the knob.
- Step 3.** If the Test Software determines that channel power must be calibrated before testing, it will prompt you to disconnect all cables from the Test Set. Disconnect any cables, and press **k1 (Proceed)**.
- Step 4.** Scroll to the **Loss Measurement Type** field and press the knob to toggle the setting to **Swept** or **Discrete**.

If you select **swept**, the Test Software will measure the loss over the frequency range that you specify. The following four fields will appear below. In each instance, either enter the number by turning the knob to the desired value and pressing it, or enter the number using the DATA ENTRY keys, then either press the knob or the **Enter** key to select it.

- **Start Frequency [MHz]** – Enter the start frequency.
- **Stop Frequency [MHz]** – Enter the stop frequency.

- **Maximum Expected Loss [dB]** – Enter the loss for the device being tested. The Test Software will use this value to adjust the scale on the results plot. Use a value slightly greater than expected for the best display resolution.
- **Duplex Out Level [dBm]** – Enter the setting for the appropriate level into the device being tested. This may be adjusted if necessary.

If you select **Discrete**, the Test Software will measure the loss at the frequency that you specify by entering the **Channel Number** to be tested. The **Channel Number** field will appear below. Enter the number by turning the knob to the desired value and pressing the knob, or use the DATA ENTRY keys to enter the number and then either press the knob or the **Enter** key to select it.

Step 5. Press the **k1 (Run)** key.

Step 6. Follow the on-screen prompts to connect the 6-dB pads, cables, and the SWR bridge, then press the **k1(Proceed)** key.

Step 7. The Test Software will turn on the source and make a reference measurement and display a connection diagram. Follow the on-screen prompts to connect the DUT (Device-Under-Test), then press the **k1(Proceed)** key.

Review the Results

If you have selected a discrete measurement, the Test Software will display the VSWR and the return loss as a single numeric value (in units of dB).

If you have selected a swept measurement, the Test Software will display the loss as a spectrum analyzer plot of loss versus frequency.

If you wish to record the spectrum analyzer plot of the results of a swept measurement, press the **k5 (Scr Dump)** key. This will cause the Test Software to pause automated operation to print a summary of the plot. Press the **Print** key to send the plot to a PC connected to the Test Set. After the summary has printed in the BTS Laptop Utility program **Test Set Screen Capture** window, press the **k2 (Continue)** key to re-start the Test Software at the point at which it paused. You may save the window contents to a file in the PC.

Press the **k1 (Proceed)** key to display the frequency range settings, the maximum and minimum return losses, and the maximum and minimum VSWR for the test. From this point, you may press the **k1 (Repeat)** key to test another cable or device, press the **k5 (Return)** key once to return to the Insertion Loss Test setup menu, or press the **k5 (Return)** key twice to return to the Calibration/Utilities Menu.

5 Reference

This chapter describes Test Software operational details that were not covered in [Chapter 2, “Installation,”](#) on page 21, [Chapter 3, “Connections,”](#) on page 57, and [Chapter 4, “Performing Tests,”](#) on page 61. The information in this chapter is organized by key topics, listed alphabetically.

Overview

Refer to the following topic areas for detailed instructions on Test Software use:

[“Accessing Test Software Functions” on page 101.](#)

[“BTS Laptop Utility Program Windows” on page 117.](#)

[“Demo \(Demonstration\) Mode” on page 120.](#)

[“Parameters” on page 122.](#)

[“Specifications \(Pass/Fail Limits\)” on page 129.](#)

[“Testing without MSC Control” on page 132.](#)

[“Using a PC Card” on page 133.](#)

Accessing Test Software Functions

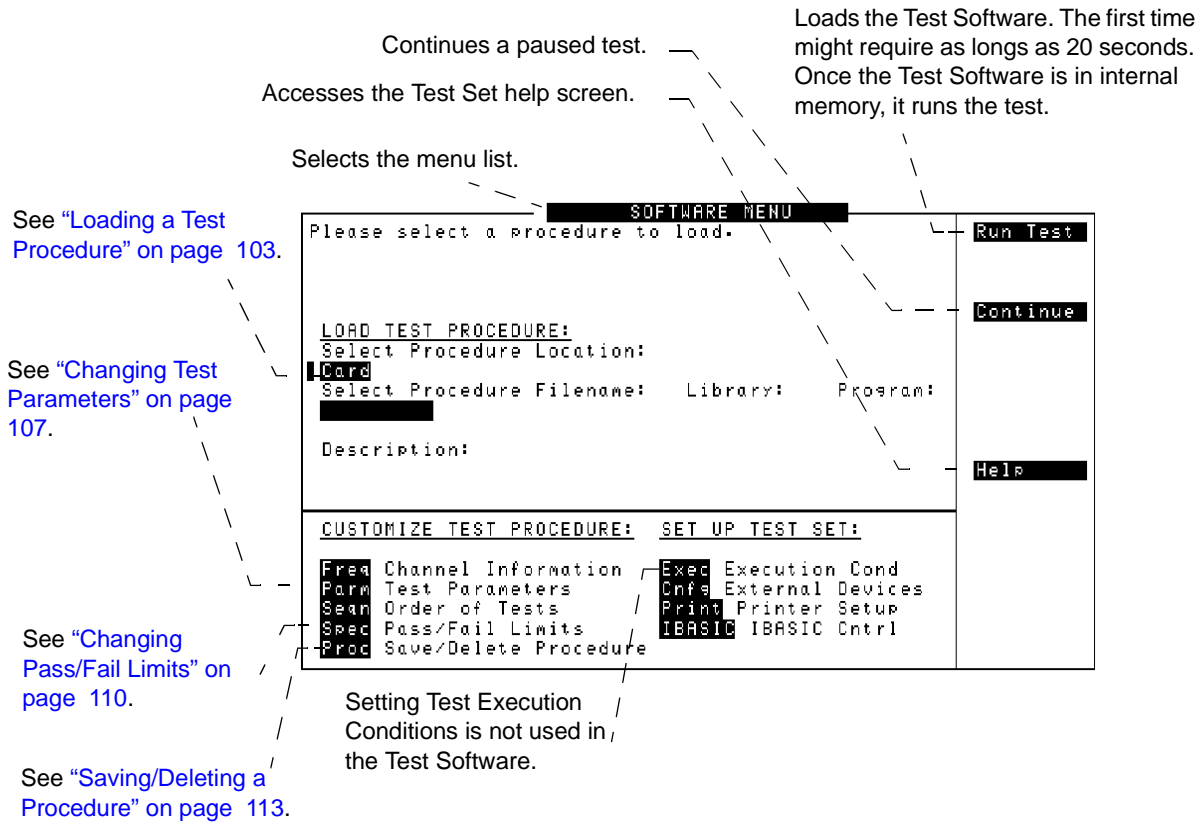
Test Software functions may be accessed from the various menu screens. These include the SOFTWARE MENU screen, which is the master screen from which the others are reached. The following eight sub-sections describe the screens and the functions accessed from those screens.

- “SOFTWARE MENU Screen Overview” on page 102
- “Loading a Test Procedure” on page 103
- “Loading the Test Software Card and Procedure” on page 104
- “Customizing a Test Procedure” on page 106
- “Changing Test Parameters” on page 107
- “Changing Pass/Fail Limits” on page 110
- “Saving/Deleting a Procedure” on page 113

SOFTWARE MENU Screen Overview

Pressing the front-panel Menu key will cause the Test Set to display the SOFTWARE MENU screen (see Figure 5-1). This screen allows the user to configure and run custom Test Software, access help, proceed with a paused procedure, or access additional test screens.

Figure 5-1 SOFTWARE MENU Screen

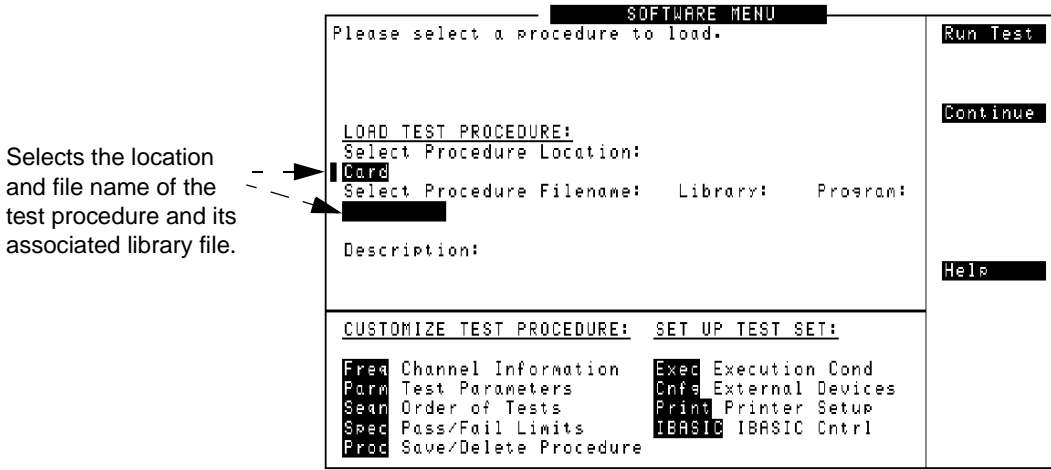


Loading a Test Procedure

Before you begin testing, you must load the Test Software into the Test Set memory (see [Figure 5-2](#)). To load the Test Software, select the location where the procedure currently resides (in this case, it will be a PC card) and a procedure file name to download into the Test Set memory. The card comes pre-programmed with at least one procedure.

The first time that you select a procedure, the actual Test Software program is not loaded into the Test Set memory until you press the Test Set **k1 (Run Test)** key. It will take approximately 20 seconds for the Test Software program to load. The program will remain in memory after a power-down/power-up cycle, unless it is manually deleted or a new program is loaded.

Figure 5-2 Loading a Test Procedure



NOTE See [“Troubleshooting the Test Software Installation” on page 137](#) for some hints to help debug any problems that you might have during the installation of the Test Software.

Reference

Loading the Test Software Card and Procedure

Load the Test Software card and a procedure as shown in [Figure 5-3](#) and [Figure 5-4](#).

Figure 5-3 Loading the Test Software Card

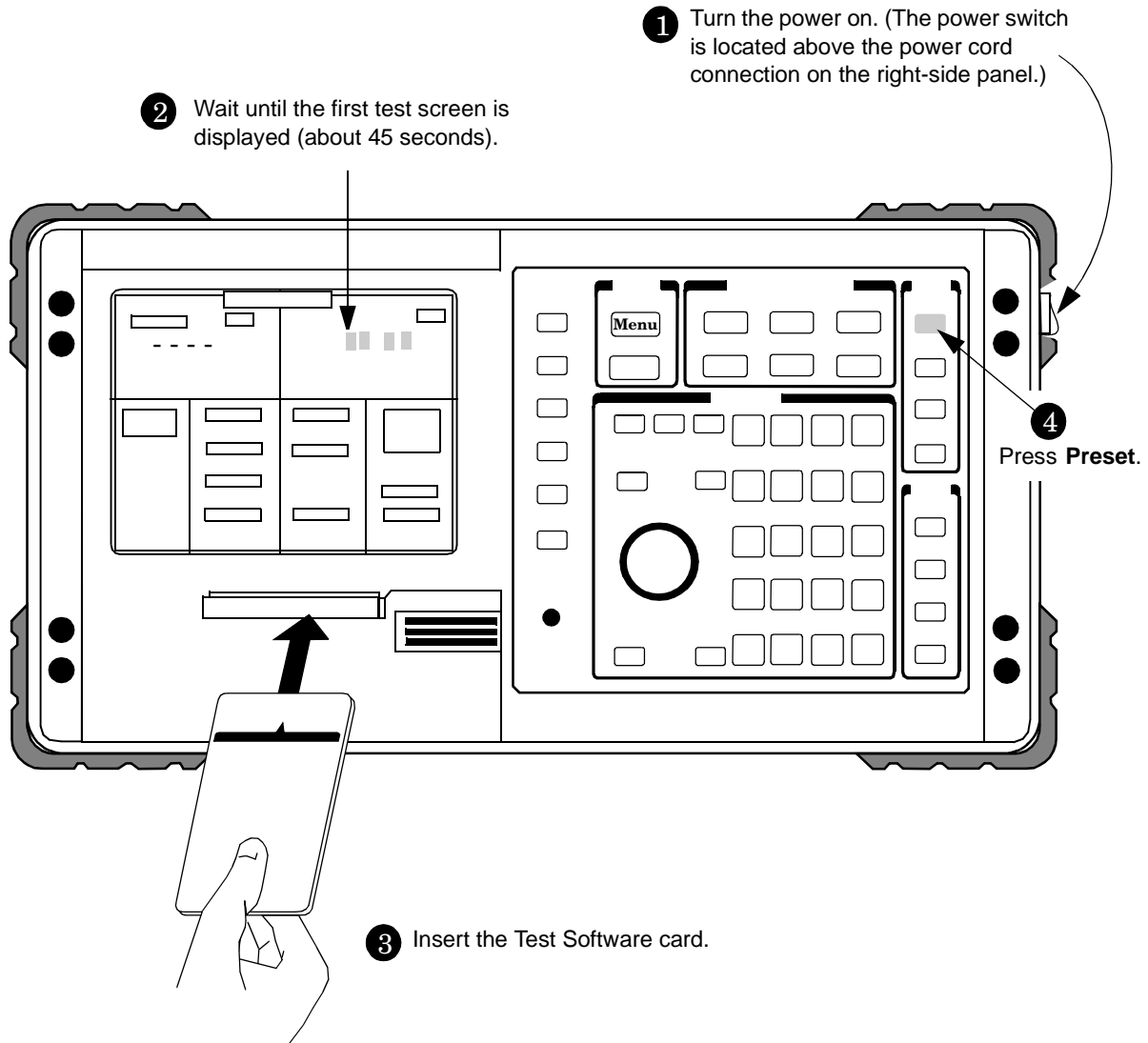
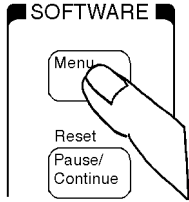







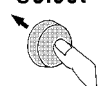




Figure 5-4 Loading a Procedure

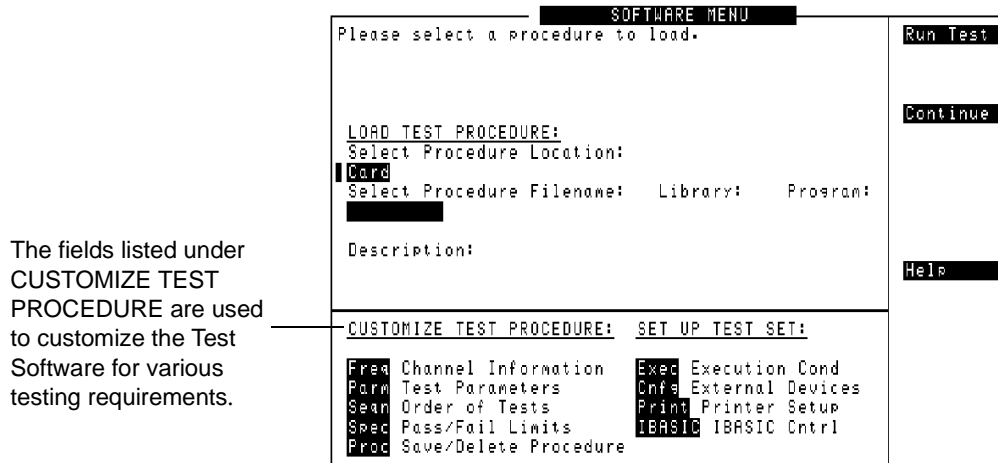
<p>5 Press the Menu key to display the SOFTWARE MENU screen.</p> 	<p>6 Scroll to Select Procedure Location: and select it.</p> <p>Position</p>  <pre>LOAD TEST PROCEDURE: Select Procedure Location: █ Select Procedure Filename: █</pre> <p>Select</p> 
<p>7 Scroll to Card and select it.</p> <p>Position</p>  <pre>Choices: █ Card ROM RAM</pre> <p>Position</p> 	<p>8 Scroll to Select Procedure Filename: and select it.</p> <p>Position</p>  <pre>LOAD TEST PROCEDURE: Select Procedure Location: Card Select Procedure Filename: █</pre> <p>Select</p> 
<p>9 Scroll to Choices: and select the Procedure name: OUT_SVC.</p> <p>Position</p>  <pre>Choices: █ DEMO LTDMA</pre> <p>Select</p> 	<p>10 Scroll to Run Test and select it. The Test Software will load.</p> <p>Position</p>  <pre>1 Run Test 2 Continue 4 Help</pre> <p>Select</p>  <p>⌚ Loading Time: First time: approximately 20 seconds. After first time: approximately 8 seconds.</p>

Reference

Customizing a Test Procedure

Test Software packages have been designed so that you may make changes easily from the Test Set front panel (see [Figure 5-5](#)). For example, you may insert or delete tests, and later, after running the tests, you may change the pass/fail limits or decide to test different channels. You may store the customized test procedure on an SRAM card so that you may skip these steps in the future, see [“Saving/Deleting a Procedure”](#) on page 113.

Figure 5-5 Customizing a Test Procedure



NOTE

The Test Software package might not allow customization of testing procedures. If you attempt to enter a customization screen that is not supported with the current package, the message “Access to secure test information denied” will be displayed.

Changing Test Parameters

The Test Software uses parameters to optimize the test environment and conditions for the testing situation. The default test parameters are determined by examining the test requirements and specifications from the equipment manufacturer. The Test Software comes with default settings for all test parameters.

Press the **Menu** key, then select the **Parm Test Parameters** field to display the TESTS (Test Parameters) screen (see [Figure 5-6](#)).

The fields in the TESTS (Test Parameters) screen allow you to change test parameters to optimize the testing conditions (see [Figure 5-7](#) and [Figure 5-8](#)). For information on saving customized test parameters, see “Saving/Deleting a Procedure” on page 113.

Figure 5-6 TESTS (Test Parameters) Screen

Parameter description. The descriptions for the Test Software might be different than shown here.

Selects the parameter to be changed.

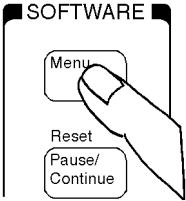







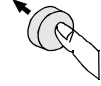

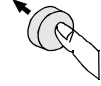

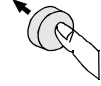

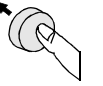

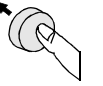

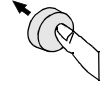

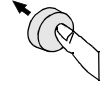

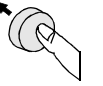

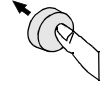
Displays the current parameter setting.

Param#	Description	Value	Units
1	Adjust Power [0=no 1=on fail 2=always]	0.000000	
2	BBA Chan Stand [1=NAC 2=NAP 3=KP4]		
3	BBA Channel Number		
4	BBA PN Offset		
5	GN Code Domain Power Threshold		
6	GN Print Inactive Codes [0=no 1=yes]		
7	GN Stop test if results fail [0=no 1=yes]		
8	LAP Baud Rate [valid test set range]		

3 Print All
 4 Help
 5 Main Menu

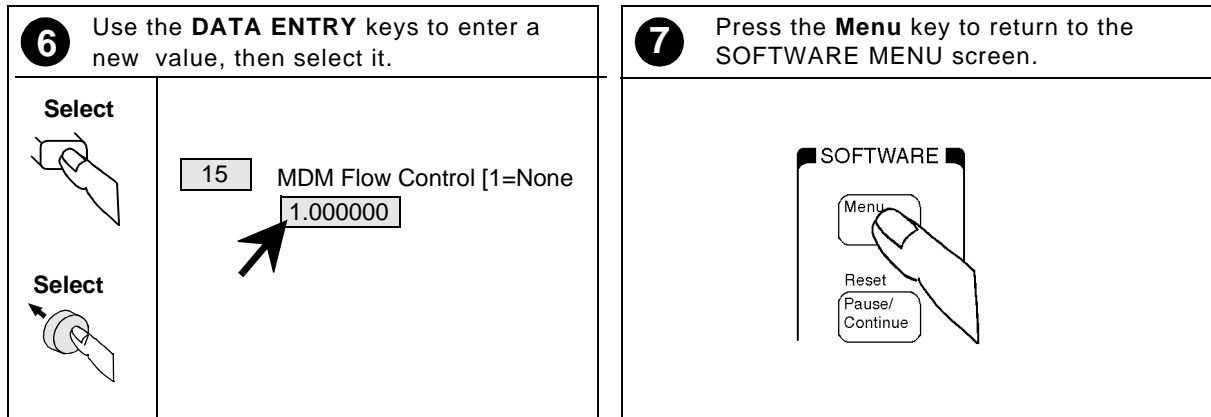
NOTE The TESTS (Test Parameters) screen might not be used in the particular Test Software package that you are using, or some fields might not be present, depending on the Test Software application. The message “Access to secure test information denied” will be displayed if the screen is not supported in the Test Software package.

Figure 5-7 Changing Test Parameters

<p>1 Press the Menu key to display the SOFTWARE MENU screen.</p> <p>If the Test Software is running, press Shift, Pause/Continue before pressing Menu.</p> 	<p>2 Scroll to Parm Test Parameters and select it.</p> <table border="1"> <tr> <td data-bbox="828 380 967 499"> <p>Position</p>  </td> <td data-bbox="980 415 1414 562"> <table border="1"> <tr><td>Freq</td><td>Channel Information</td></tr> <tr><td>Parm</td><td>Test Parameters</td></tr> <tr><td>Seqn</td><td>Order of Tests</td></tr> <tr><td>Spec</td><td>Pass Fail Limits</td></tr> <tr><td>Proc</td><td>Save/Delete Procedure</td></tr> </table> </td> </tr> <tr> <td data-bbox="828 541 967 661"> <p>Select</p>  </td> <td></td> </tr> </table>	<p>Position</p> 	<table border="1"> <tr><td>Freq</td><td>Channel Information</td></tr> <tr><td>Parm</td><td>Test Parameters</td></tr> <tr><td>Seqn</td><td>Order of Tests</td></tr> <tr><td>Spec</td><td>Pass Fail Limits</td></tr> <tr><td>Proc</td><td>Save/Delete Procedure</td></tr> </table>	Freq	Channel Information	Parm	Test Parameters	Seqn	Order of Tests	Spec	Pass Fail Limits	Proc	Save/Delete Procedure	<p>Select</p> 	
<p>Position</p> 	<table border="1"> <tr><td>Freq</td><td>Channel Information</td></tr> <tr><td>Parm</td><td>Test Parameters</td></tr> <tr><td>Seqn</td><td>Order of Tests</td></tr> <tr><td>Spec</td><td>Pass Fail Limits</td></tr> <tr><td>Proc</td><td>Save/Delete Procedure</td></tr> </table>	Freq	Channel Information	Parm	Test Parameters	Seqn	Order of Tests	Spec	Pass Fail Limits	Proc	Save/Delete Procedure				
Freq	Channel Information														
Parm	Test Parameters														
Seqn	Order of Tests														
Spec	Pass Fail Limits														
Proc	Save/Delete Procedure														
<p>Select</p> 															
<p>The TESTS (Test Parameters) screen appears on the display.</p>	<p>3 Scroll to Parm # and select it.</p> <p>(Entries on the display might be different.)</p> <table border="1"> <tr> <td data-bbox="828 821 967 940"> <p>Position</p>  </td> <td data-bbox="980 905 1414 982"> <table border="1"> <tr><td>1</td><td>Adjust Power [0=no 1=on f</td></tr> <tr><td>0.00000</td><td></td></tr> </table> </td> </tr> <tr> <td data-bbox="828 982 967 1102"> <p>Select</p>  </td> <td></td> </tr> </table>	<p>Position</p> 	<table border="1"> <tr><td>1</td><td>Adjust Power [0=no 1=on f</td></tr> <tr><td>0.00000</td><td></td></tr> </table>	1	Adjust Power [0=no 1=on f	0.00000		<p>Select</p> 							
<p>Position</p> 	<table border="1"> <tr><td>1</td><td>Adjust Power [0=no 1=on f</td></tr> <tr><td>0.00000</td><td></td></tr> </table>	1	Adjust Power [0=no 1=on f	0.00000											
1	Adjust Power [0=no 1=on f														
0.00000															
<p>Select</p> 															
<p>4 Scroll to the Parm # to be changed and select it.</p> <table border="1"> <tr> <td data-bbox="212 1241 352 1381"> <p>Scroll</p>  </td> <td data-bbox="365 1255 797 1381"> <p>(This parameter number and description are examples.)</p> <table border="1"> <tr><td>15</td><td>MDM Flow Control [1=None</td></tr> </table> </td> </tr> <tr> <td data-bbox="212 1423 352 1543"> <p>Select</p>  </td> <td></td> </tr> </table>	<p>Scroll</p> 	<p>(This parameter number and description are examples.)</p> <table border="1"> <tr><td>15</td><td>MDM Flow Control [1=None</td></tr> </table>	15	MDM Flow Control [1=None	<p>Select</p> 		<p>5 Scroll to Value and select it.</p> <table border="1"> <tr> <td data-bbox="828 1262 967 1381"> <p>Position</p>  </td> <td data-bbox="980 1346 1414 1423"> <table border="1"> <tr><td>15</td><td>MDM Flow Control [1=None</td></tr> <tr><td>0.000000</td><td></td></tr> </table> </td> </tr> <tr> <td data-bbox="828 1423 967 1543"> <p>Select</p>  </td> <td></td> </tr> </table>	<p>Position</p> 	<table border="1"> <tr><td>15</td><td>MDM Flow Control [1=None</td></tr> <tr><td>0.000000</td><td></td></tr> </table>	15	MDM Flow Control [1=None	0.000000		<p>Select</p> 	
<p>Scroll</p> 	<p>(This parameter number and description are examples.)</p> <table border="1"> <tr><td>15</td><td>MDM Flow Control [1=None</td></tr> </table>	15	MDM Flow Control [1=None												
15	MDM Flow Control [1=None														
<p>Select</p> 															
<p>Position</p> 	<table border="1"> <tr><td>15</td><td>MDM Flow Control [1=None</td></tr> <tr><td>0.000000</td><td></td></tr> </table>	15	MDM Flow Control [1=None	0.000000											
15	MDM Flow Control [1=None														
0.000000															
<p>Select</p> 															

Continue on next page

Figure 5-8 Changing Test Parameters (continued)



Reference

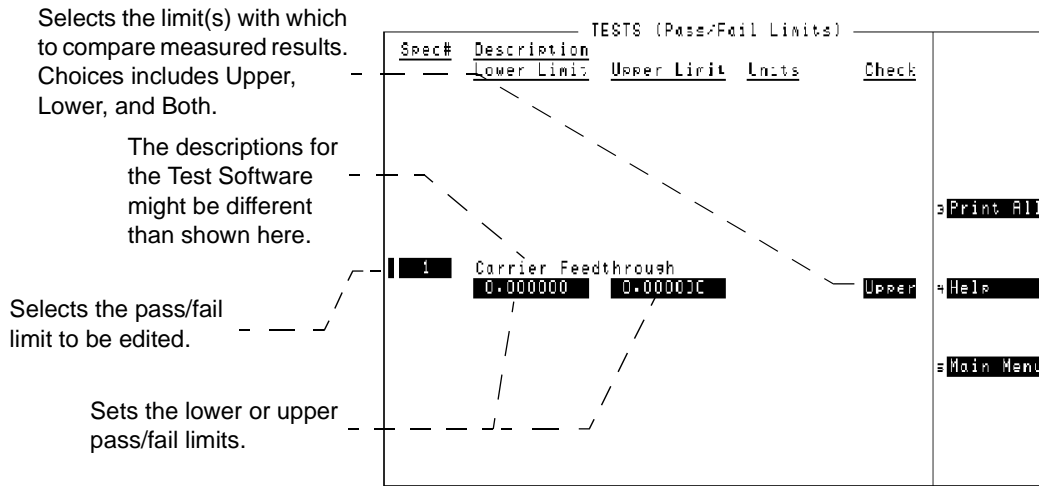
Changing Pass/Fail Limits

Pass/Fail limits define the values with which a measurement result is compared to determine if the Base Station under test meets the specified standards. Default values are set in the Test Software. These default values may be changed to suit particular requirements.

Press the **Menu** key, then select the **Spec Pass/Fail Limits** field to display the TESTS (Pass/Fail Limits) screen (see [Figure 5-9](#)).

The fields in the TESTS (Pass/Fail Limits) screen allow you to change the pass/fail limits to optimize the testing conditions (see [Figure 5-10](#) and [Figure 5-11](#)). For information on saving customized pass/fail limits, see “Saving/Deleting a Procedure” on page 113.

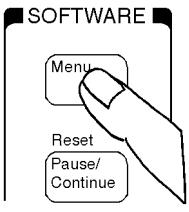

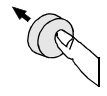

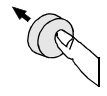

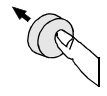

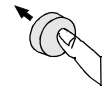
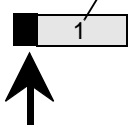

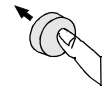
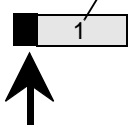

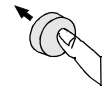
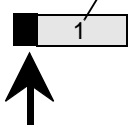


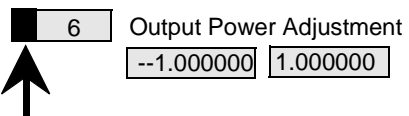


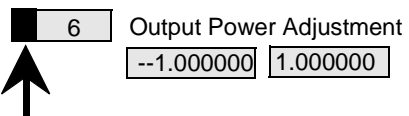

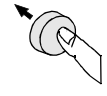
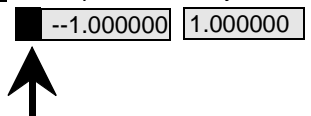

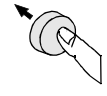
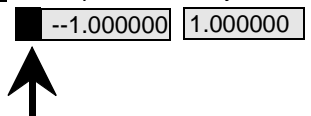


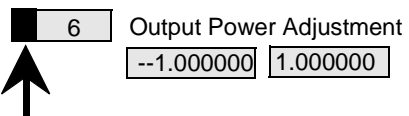

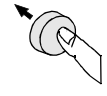
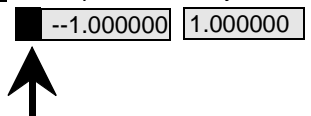
Figure 5-9 TESTS (Pass/Fail Limits) Screen



NOTE

The TESTS (Pass/Fail Limits) screen might not be used in the particular Test Software package that you are using, or some fields might not be present, depending on the Test Software application. The message “Access to secure test information denied” will be displayed if the screen is not supported in the Test Software package.

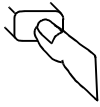
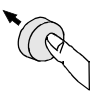


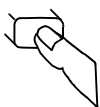
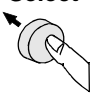

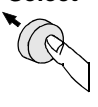

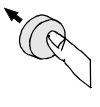

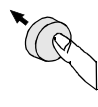
Figure 5-10 Changing Pass/Fail Limits

<p>1 Press the Menu key to display the SOFTWARE MENU screen.</p> <p>If the Test Software is running, press Shift, Pause/Continue before pressing Menu.</p> 	<p>2 Scroll to Spec Pass/Fail Limits and select it.</p> <table border="1"> <tr> <td data-bbox="836 378 966 493"> <p>Position</p>  </td> <td data-bbox="1031 451 1388 619"> <p>Freq Channel Information Parm Test Parameters Seqn Order of Tests Spec Pass/Fail Limits Proc Save/Delete Procedure</p> </td> </tr> <tr> <td data-bbox="836 535 966 661"> <p>Select</p>  </td> <td></td> </tr> </table>	<p>Position</p> 	<p>Freq Channel Information Parm Test Parameters Seqn Order of Tests Spec Pass/Fail Limits Proc Save/Delete Procedure</p>	<p>Select</p> 					
<p>Position</p> 	<p>Freq Channel Information Parm Test Parameters Seqn Order of Tests Spec Pass/Fail Limits Proc Save/Delete Procedure</p>								
<p>Select</p> 									
<p>The TESTS (Pass/Fail Limits) screen appears on the display.</p>	<p>3 Scroll to Spec # and select it.</p> <table border="1"> <tr> <td data-bbox="836 819 966 934"> <p>Position</p>  </td> <td data-bbox="1112 850 1388 892"> <p>(Disregard this number.)</p> </td> </tr> <tr> <td data-bbox="836 976 966 1102"> <p>Select</p>  </td> <td data-bbox="1096 913 1226 1039">  </td> </tr> </table>	<p>Position</p> 	<p>(Disregard this number.)</p>	<p>Select</p> 					
<p>Position</p> 	<p>(Disregard this number.)</p>								
<p>Select</p> 									
<p>4 Scroll to the desired Spec # and select it.</p> <table border="1"> <tr> <td data-bbox="219 1260 332 1375"> <p>Scroll</p>  </td> <td data-bbox="422 1249 738 1291"> <p>(This Spec # is an example.)</p> </td> </tr> <tr> <td data-bbox="219 1417 332 1543"> <p>Select</p>  </td> <td data-bbox="365 1344 771 1459">  </td> </tr> </table>	<p>Scroll</p> 	<p>(This Spec # is an example.)</p>	<p>Select</p> 		<p>5 Scroll to Lower Limit and select it.</p> <table border="1"> <tr> <td data-bbox="836 1260 966 1375"> <p>Position</p>  </td> <td data-bbox="1006 1312 1404 1386"> <p>6 Output Power Adjustment</p> </td> </tr> <tr> <td data-bbox="836 1417 966 1543"> <p>Select</p>  </td> <td data-bbox="1079 1344 1388 1459">  </td> </tr> </table>	<p>Position</p> 	<p>6 Output Power Adjustment</p>	<p>Select</p> 	
<p>Scroll</p> 	<p>(This Spec # is an example.)</p>								
<p>Select</p> 									
<p>Position</p> 	<p>6 Output Power Adjustment</p>								
<p>Select</p> 									

Continue on next page

Reference

Figure 5-11 Changing Pass/Fail Limits (continued)

<p>6 Use the DATA ENTRY keys to enter a new value, then select it.</p> <p>Enter</p>  <p>6 Output Power Adjustment</p> <p><input type="checkbox"/> -0.500000 <input type="checkbox"/> 1.000000</p> <p>Select</p>  <p>(Enter the desired value.)</p>	<p>7 Scroll to Upper Limit and select it.</p> <p>Position</p>  <p>Output Power Adjustment</p> <p>.500000 <input checked="" type="checkbox"/> 1.000000 dB</p> <p>Select</p>  <p>↑</p>
<p>8 Use the DATA ENTRY keys to enter a new value, then select it.</p> <p>Enter</p>  <p>Output Power Adjustment</p> <p>.500000 <input checked="" type="checkbox"/> 0.500000 dB</p> <p>Select</p>  <p>(Enter the desired value.)</p>	<p>9 Scroll to Check and select it.</p> <p>Position</p>  <p><input checked="" type="checkbox"/> Both</p> <p>Select</p>  <p>↑</p>
<p>10 Select the choice that should apply to testing and select it.</p> <p>Position</p>  <p>Select</p>  <p>→</p> <p>Choices:</p> <p>Upper</p> <p>Lower</p> <p><input checked="" type="checkbox"/> Both</p> <p>None</p>	<p>11 Press the Menu key to return to the SOFTWARE MENU screen.</p> <p>Position</p>  <p>Select</p>  <p>SOFTWARE</p> <p>Menu</p> <p>Reset</p> <p>Pause/Continue</p>

Saving/Deleting a Procedure

A test procedure is a collection of channel information, test parameters, testing order, and pass/fail limits saved in a file that customizes the Test Software to a specific application. Ordinarily, procedures are saved on an SRAM card.

Press the **Menu** key, then select the **Proc Save/Delete Procedure** field to display the TESTS (Save/Delete Procedure) screen (see [Figure 5-12](#)).

The fields in the TESTS (Save/Delete Procedure) screen allow you to save or delete procedures (see [Figure 5-13](#), [Figure 5-14](#), and [Figure 5-15](#)). When you save a procedure, you save channel information, test parameters, pass/fail limits, and testing order, plus a library that contains the names of all test parameters, pass/fail limits, and tests that are resident in the Test Software. The library file comes from the Test Software and cannot be modified. The library file will be automatically saved on the card that is being used to store the new test procedure.

The process for deleting a procedure is the same as saving a procedure, except that, in Step13, select the **Del Proc** field instead.

Figure 5-12 TESTS (Save/Delete Procedure) Screen

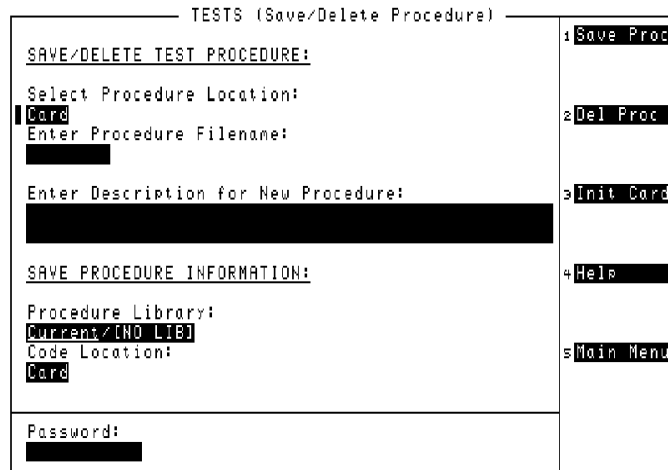
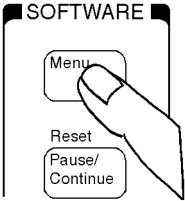



















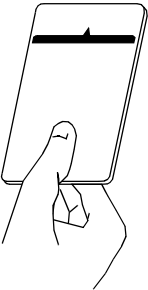

















Figure 5-13 Saving a Test Procedure

<p>1 Press the Menu key to display the SOFTWARE MENU screen.</p> <p>If the Test Software is running, press Shift, Pause/Continue before pressing Menu.</p> 	<p>2 Scroll to Proc Save/Delete Procedure and select it.</p> <table border="1"> <tr> <td data-bbox="829 390 964 506"> <p>Position</p>  </td> <td data-bbox="1036 422 1393 583"> <table border="1"> <tr><td>Freq</td><td>Channel Information</td></tr> <tr><td>Parm</td><td>Test Parameters</td></tr> <tr><td>Seqn</td><td>Order of Tests</td></tr> <tr><td>Spec</td><td>Pass Fall Limits</td></tr> <tr><td>Proc</td><td>Save/Delete Procedure</td></tr> </table> </td> </tr> <tr> <td data-bbox="829 541 964 657"> <p>Select</p>  </td> <td></td> </tr> </table>	<p>Position</p> 	<table border="1"> <tr><td>Freq</td><td>Channel Information</td></tr> <tr><td>Parm</td><td>Test Parameters</td></tr> <tr><td>Seqn</td><td>Order of Tests</td></tr> <tr><td>Spec</td><td>Pass Fall Limits</td></tr> <tr><td>Proc</td><td>Save/Delete Procedure</td></tr> </table>	Freq	Channel Information	Parm	Test Parameters	Seqn	Order of Tests	Spec	Pass Fall Limits	Proc	Save/Delete Procedure	<p>Select</p> 	
<p>Position</p> 	<table border="1"> <tr><td>Freq</td><td>Channel Information</td></tr> <tr><td>Parm</td><td>Test Parameters</td></tr> <tr><td>Seqn</td><td>Order of Tests</td></tr> <tr><td>Spec</td><td>Pass Fall Limits</td></tr> <tr><td>Proc</td><td>Save/Delete Procedure</td></tr> </table>	Freq	Channel Information	Parm	Test Parameters	Seqn	Order of Tests	Spec	Pass Fall Limits	Proc	Save/Delete Procedure				
Freq	Channel Information														
Parm	Test Parameters														
Seqn	Order of Tests														
Spec	Pass Fall Limits														
Proc	Save/Delete Procedure														
<p>Select</p> 															
<p>The TESTS (Save/Delete Procedure) screen appears on the Test Set display.</p>	<p>3 Scroll to Select Procedure Location: and select it.</p> <table border="1"> <tr> <td data-bbox="829 831 964 947"> <p>Position</p>  </td> <td data-bbox="1036 905 1333 936"> <p>Select Procedure Location:</p> </td> </tr> <tr> <td data-bbox="829 989 964 1104"> <p>Select</p>  </td> <td data-bbox="1036 940 1138 1056">  </td> </tr> </table>	<p>Position</p> 	<p>Select Procedure Location:</p>	<p>Select</p> 											
<p>Position</p> 	<p>Select Procedure Location:</p>														
<p>Select</p> 															
<p>4 Scroll to Card and select it.</p> <table border="1"> <tr> <td data-bbox="224 1272 326 1388"> <p>Position</p>  </td> <td data-bbox="435 1283 651 1430"> <p>Choices:</p> <table border="1"> <tr><td>■ Card</td></tr> <tr><td>RAM</td></tr> <tr><td>Disk</td></tr> </table> </td> </tr> <tr> <td data-bbox="224 1430 326 1545"> <p>Select</p>  </td> <td data-bbox="370 1451 711 1507"> <p>(You may also save procedures to an internal RAM disk.)</p> </td> </tr> </table>	<p>Position</p> 	<p>Choices:</p> <table border="1"> <tr><td>■ Card</td></tr> <tr><td>RAM</td></tr> <tr><td>Disk</td></tr> </table>	■ Card	RAM	Disk	<p>Select</p> 	<p>(You may also save procedures to an internal RAM disk.)</p>	<p>5 Insert an initialized PC card into the front-panel card slot.</p> <p>For detailed SRAM card initialization instructions, see "Initializing a PC Card" on page 133.</p> 							
<p>Position</p> 	<p>Choices:</p> <table border="1"> <tr><td>■ Card</td></tr> <tr><td>RAM</td></tr> <tr><td>Disk</td></tr> </table>	■ Card	RAM	Disk											
■ Card															
RAM															
Disk															
<p>Select</p> 	<p>(You may also save procedures to an internal RAM disk.)</p>														

Continue on next page





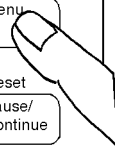
Figure 5-14 Saving a Test Procedure (continued)

<p>6 Scroll to Enter Procedure Filename: and select it.</p>	<p>7 Select characters to name the Procedure, then select Done.</p>
<p>Position </p> <p>Enter Procedure Filename: </p> <p>Select </p>	<p>Position </p> <p>Choices: Done Position Over/Ins Delete Del End Bk space A B C</p> <p>Select </p>
<p>8 Scroll to Enter Description for New Procedure: and select it.</p>	<p>9 Select characters for the description, then select Done.</p>
<p>Position </p> <p>Enter Description for New Procedure </p> <p>Select </p>	<p>Position </p> <p>Choices: Done Position Over/Ins Delete Del End Bk space A B C</p> <p>Select </p>
<p>10 Scroll to Procedure Library: and select Current.</p>	<p>11 Scroll to Code Location: and select it.</p>
<p>Position </p> <p>Procedure Library: <u>C</u>urrent / [NO LIB]</p> <p>Select </p> <p>(The underline indicates which option is selected. Pressing the knob changes the selection.)</p>	<p></p>

Continue on next page

Reference

Figure 5-15 Saving a Test Procedure (continued)

12 Scroll to Card and select it.	13 Scroll to Save Proc and select it or press k1 .
<div style="display: flex; align-items: center;"> <div style="margin-right: 20px;"> <p>Position</p>  </div> <div style="margin-right: 20px;"> <p>→</p> </div> <div style="border: 1px solid black; padding: 5px;"> <p>Choices:</p> <ul style="list-style-type: none"> ■ Card RAM Disk </div> </div> <div style="margin-top: 20px;"> <p>Select</p>  </div>	<div style="display: flex; align-items: center;"> <div style="margin-right: 20px;"> <p>Position</p>  </div> <div style="margin-right: 20px;"> <p>→</p> </div> <div style="border: 1px solid black; padding: 5px;"> <ul style="list-style-type: none"> ■ Save Proc 2 Del Proc 3 Init Card 4 Help 5 Main Menu </div> </div> <div style="margin-top: 20px;"> <p>Select</p>  </div>
14 Press the Menu key to return to the SOFTWARE MENU screen. <div style="border: 1px solid black; padding: 10px; margin: 10px auto; width: 80%;"> <div style="border: 1px solid black; padding: 5px; width: fit-content; margin: 0 auto;"> <p>SOFTWARE</p> <div style="display: flex; flex-direction: column; align-items: center; gap: 10px;"> <div style="border: 1px solid black; padding: 2px 10px; border-radius: 5px;">Menu</div> <div style="border: 1px solid black; padding: 2px 10px; border-radius: 5px;">Reset</div> <div style="border: 1px solid black; padding: 2px 10px; border-radius: 5px;">Pause/ Continue</div> </div>  </div> </div>	
15 To run the saved procedure, follow the instructions below. <ol style="list-style-type: none"> 1) Insert the PC card with the saved procedure. 2) On the SOFTWARE MENU screen, a) select the Select Procedure Location: field then select Card, b) select Select Procedure Filename:, then select the saved file name. 3) Remove the PC card, then insert the original PC card¹. 4) Press the k1 (Run Test) key. <p>¹The original Test Software card contains the full program required to run procedures. The procedure cannot run without using the original IBASIC program code on the factory card.</p>	

BTS Laptop Utility Program Windows

The BTS Laptop Utility program provides five windows in which information may be display or entered. These windows are: **Switch Terminal**, **Test Set Terminal**, **Other Data**, **Test Results**, and **Test Set Screen Capture**.

For information on installing the BTS Laptop Utility program and configuring the PC and Test Set to work together, see [“Operating the BTS Laptop Utility Program” on page 27](#).

Switch Terminal Window

The Switch Terminal window functions as essentially a VT100 terminal to accomplish the following:

- It allows you to connect with the MSC, either with the PC internal modem to dial into the MSC, or with the PC and a telnet connection to the MSC.
- It displays the commands sent to the MSC and the replies sent back from the MSC.

Test Set Terminal Window

The Test Set Terminal window displays commands sent from the Test Set to the MSC.

Other Data Window

The **Other Data** window accomplishes the following:

- It allows you to download frequency plans to the Test Set.
- It displays short-form test results.

The short-form test results are sent to the PC automatically and displayed in the window (see [Figure 5-16](#) for an example of the display). By selecting **File, Logging Enabled**, you may enter a file name to save the test results to a file that may be retrieved into a text editor and printed out. **This selection must be done before the test results are sent to the screen.**

Figure 5-16 Short-Form Test Results Example

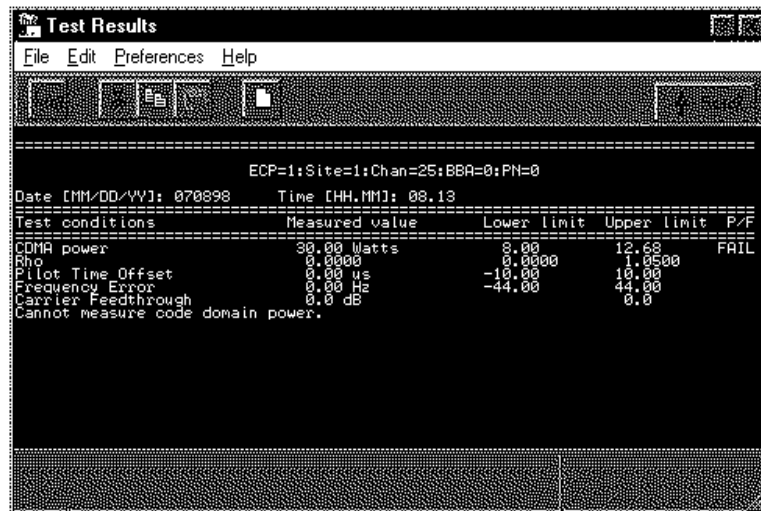


Test Results Window

The **Test Results** window displays test results. These results may be saved for later use (see [Figure 5-17](#) for an example of the display).

The test results are sent to the PC automatically and displayed in the window. By selecting **File, Logging Enabled**, you may enter a file name to save the test results to a file that may be retrieved into a text editor and printed out. **This selection must be done before the test results are sent to the screen.**

Figure 5-17 Test Results Example



Test Set Screen Capture Window

The Test Set Screen Capture window allows you to capture a Test Software screen image and save it as a bit map file for later view or use. This is very helpful when using the Test Set spectrum analyzer or when you wish to capture some other screen. Note that IBASIC program operation must be paused first, by pressing the Pause/Continue key, to print any of the TESTS screens used for automated testing.

To capture a Test Software screen, configure the PC and the Test Set, then attempt a screen capture, as follows:

1. If the Test Set SERIAL 9 port and the PC serial port are not configured, configure both ports (see [“Configuring the Test Set and PC Serial Ports for Communication with the Test Set”](#) on page 29).
2. Select the screen that you wish to save and make any required entries on that screen to display the desired information.
3. If the screen that you intend to capture is one that appears only when the Test Software is running (a star appears in the upper right-hand corner of the display), press the **Pause/Continue** key to pause it.
4. Press the Test Set **Shift** key, then the **Inst Config (I/O Config)** key. The Test Set will display the I/O CONFIGURE screen.
5. Select the **Serial_9 In** field and press the knob to toggle the setting to **Inst** (underlined).
6. Press the Test Set **Shift** key, then the **Print (Printer Config)** key. The Test Set will display the PRINTER CONFIGURE screen.
7. Select the **Model** field and select **DeskJet** from the drop-down **Choices:** list.
8. Select the **Printer Port** field and select **Serial 9** from the drop-down **Choices:** list.
9. If the screen of interest is one that appears only when the Test Software is running, press the **Menu** key. The Test Software will display the SOFTWARE MENU screen.
10. If the screen of interest is one that appears only when the Test Software is running, select the **IBASIC IBASIC Cntrl** field. The Test Software will display again the screen that you set up in Step 2.
11. Press the Test Set **Print** key. The currently-displayed screen should appear in the **Test Set Screen Capture** window on the PC screen.
12. If the screen is satisfactory and you wish to use or view it later, enter a name for the file in the **Test Set Screen Capture** window **Title** field.
13. On the **Test Set Screen Capture** window tool bar, click on the third button from the left (**Save Image**).
14. On the drop-down **Save** window, select the location to which you wish to save the image. Make certain that the **Save as type:** field is set to **.bmp**, and click on **Save**. The file will be saved as a bit-mapped image in the location that you selected.

Demo (Demonstration) Mode

The demonstration mode offers a good method for becoming familiar with the operation of the Test Software. Demo mode allows you to step through the menus and simulate testing without a PC, a connection to the switch, or even a Base Station.

In the demo mode, the system will not send commands to the MSC, but it will perform very much the same as if actually testing a Base Station. When measurements are displayed, it provides sample numbers in order to show how the printout format will appear.

There are two methods for entering the demo mode:

- Selecting the procedure named DEMO.
and
- Selecting the demo mode using the demo control parameter (see 34. [ZZZZ Test Demo Mode \[0=normal 1=demo\]](#)).

Selecting the DEMO Procedure

Select the DEMO procedure as follows:

NOTE

Once the DEMO procedure is loaded, *it will remain in the Test Set memory until you load another procedure*. Even if you turn off the Test Set and run the Test Software later, the procedure is stored in battery-backed-up memory and will remain ready to run.

- Step 1.** If the Test Software is running, press the **Shift** key, then the **Pause/Continue** key to stop it.
- Step 2.** Press the **Menu** key. The Test Software will display the SOFTWARE MENU screen.
- Step 3.** Select the **Select Procedure Location:** field, then select **Card** from the drop-down **Choices:** list.
- Step 4.** Select the **Select Procedure Filename:** field, then select **DEMO** from the drop-down **Choices:** list.
- Step 5.** Press the **k1 (Run Test)** key to run the Test Software. The Test Software will set the demo control parameter to 1 and operate in demo mode until you load another procedure.

Selecting Demo Mode Using the Control Parameter

Select the demo mode using the control parameter as follows:

NOTE

Once the demo mode is enabled, *it will stay on until you turn it off*. Even if you turn off the Test Set and run the Test Software later, the demo mode setting is stored in non-volatile RAM and will still be set.

- Step 1.** If the Test Software is running, press the **Shift** key, then the **Pause/Continue** key to stop it.
- Step 2.** Press the **Menu** key. The Test Software will display the SOFTWARE MENU screen.

- Step 3.** Select the **Parm Test Parameters** field. The Test Software will display the TESTS (Test Parameters) screen.
- Step 4.** Select the **Parm#** field to allow scrolling.
- Step 5.** Scroll to the **ZZZZ Test Demo Mode** field and press the knob again to stop the scrolling function.
- Step 6.** Turn the knob clockwise to place the cursor to the left of the value field (**0.000000**) below the parameter name.
- Step 7.** Using the DATA ENTRY keys, enter 1.
- Step 8.** Press the **k5 (Main Menu)** key. The Test Software will display the SOFTWARE MENU screen and will operate in demo mode the next time that you run it. If you wish to re-run the Test Software now, press the **k1 (Run Test)** key.

Exiting the Demo Mode

To turn off the demo mode, enter a value of 0 in the demo mode control parameter as follows:

- Step 1.** If the Test Software is running, press the **Shift** key, then the **Pause/Continue** key to stop it.
- Step 2.** Press the **Menu** key. The Test Software will display the SOFTWARE MENU screen.
- Step 3.** Select the **Parm Test Parameters** field. The Test Software will display the TESTS (Test Parameters) screen.
- Step 4.** Select the **Parm#** field to allow scrolling.
- Step 5.** Scroll to the **ZZZZ Test Demo Mode** field and press the knob again to stop the scrolling function.
- Step 6.** Turn the knob clockwise to place the cursor to the left of the value field (**1.000000**) below the parameter name.
- Step 7.** Using the DATA ENTRY keys, enter 0.
- Step 8.** Press the **k5 (Main Menu)** key. The Test Software will display the SOFTWARE MENU screen and will operate in normal mode the next time that you run it. If you wish to re-run the Test Software now, press the **k1 (Run Test)** key.

Parameters

The Test Software uses the entries in the Test Parameters screen to customize testing and specify serial communications settings.

A special parameter allows the Test Software to run in a demonstration mode, which is useful for familiarization with the operation of the Test Set without connecting to any external equipment (see [“Demo \(Demonstration\) Mode” on page 120](#)).

Most parameters may be entered in two ways:

- By loading and running the Test Software and entering all of the information in the Test Configuration, Base Station Configuration, and Serial Port Configuration menus. The Test Software automatically changes the test parameter settings to match the configuration settings.

Parameters that may not be set while the Test Software is running include:

- 1. [Adjust TX Power \[0=no 1=on fail 2=always\]](#)
- 2. [GN MSC Command Speed \[0=slow 1=fast\]](#)
- 4. [GN Stop Test if results fail \[0=no 1=yes\]](#)
- 20. [MSC Require CP INH at Ant Port \[1=Yes\]](#)
- 33. [TX Use 230 kHz BW on Data Dev \[1=yes\]](#)
- 34. [ZZZZ Test Demo Mode \[0=normal 1=demo\]](#)

- By loading the Test Software and selecting **Parm Test Parameters** on the main SOFTWARE MENU screen. You may change the settings from the factory defaults.

This section lists the parameters and describes the use of each. For instructions on changing the parameters and saving the changes on an SRAM card, see [“Changing Test Parameters” on page 107](#) and [“Saving/Deleting a Procedure” on page 113](#).

1. **Adjust TX Power [0=no 1=on fail 2=always]**

Enter the selection to determine the manner in which power output adjustment will be made.

- If you select 0, the transmitter power output will not be adjusted, irrespective of the measurement result, and the adjustment power meter will not be displayed.
- If you select 1, the transmitter power output will be adjusted and the power meter will be displayed if the measured power is outside of the specified pass/fail limits. Adjust the power output to within the specified pass/fail limits and continue with testing.
- If you select 2, the transmitter power output will be adjusted and the power meter will be displayed, irrespective of the measurement result. Adjust the power output to within the specified pass/fail limits and continue testing.

See ["Output Power Adjustment Error" on page 130](#) and ["Output Power Error" on page 130](#).

2. GN MSC Command Speed [0=slow 1=fast]

Enter the selection to determine the speed at which commands will be sent from the Test Set through the PC to the MSC during automated testing.

- If you select 0, the measurements will be made in the most reliable manner.
- If you select 1, the measurements will be made in the most expeditious manner. This setting is most often used when using a PC running the BTS Laptop Utility and an internal modem.

3. GN Power Output [0=meas 1=spec 2=blnk]

Enter the selection to determine the manner in which output power test results will be displayed.

- If you select 0, the measured output power will be entered in the Output Power column of the FCC short form when the Full Site Test (FCC) test or Single Radio Test is run. Also, when the TX Power Adjustment test is run, the center scale value on the meter will be determined by the pass/fail limits.
- If you select 1, the value that you specify for the radio in the frequency plan, or at the start of the Single Radio Test, will be printed in the Output Power column of the FCC short form (not the measured value). The measured value will still be printed in the long form. Also, when the TX Power Adjustment test is run, the center scale value will be set to the value that you enter for the **Specified Output Power** at the start of the test.
- If you select 2, the Output Power column of the FCC short form will be left blank.

4. GN Stop Test if results fail [0=no 1=yes]

Enter the selection to determine the action of the Test Software in the event of a measurement failure. An F will appear in the P/F column of the test results to indicate a failure of that data point.

- If you select 0, the Test Software will continue running if the measured value is not within specifications.
- If you select 1, the Test Software will stop testing if the measured value is not within specifications.

5. **INST Synth Ref [1 - 9]**

Enter the selection to determine the timebase that will be used in measurements.

- **1 – 1-MHz External.** Uses an external reference. Requires that an external timebase of the indicated frequency be connected to the SYNTH REF IN connector on the Test Set. When a valid external signal is detected, the REFERENCE Unlock indicator on the front panel of the Test Set will be extinguished and the Ext Synth indicator will be lighted.
- **2 – 2-MHz External.** Same as for 1 MHz, except 2 MHz.
- **3 – 3-MHz External.** Same as for 1 MHz, except 3 MHz.
- **4 – 4.8-MHz External.** Same as for 1 MHz, except 4.8 MHz.
- **5 – 5-MHz External.** Same as for 1 MHz, except 5 MHz.
- **6 – 10-MHz External.** Same as for 1 MHz, except 10 MHz.
- **7 – 15-MHz External.** Same as for 1 MHz, except 15 MHz.
- **8 – Int OXCO.** Uses the oven-controlled crystal oscillator in the Test Set as a timebase. This is the default setting. It will be used unless an external reference signal of the correct frequency and amplitude is applied to the SYNTH REF IN connector on the Test Set.
- **9 – TDMA Ref.** Uses the TDMA analyzer reference signal in the Test Set.

6. **INST TDMA Ref[1 - 6]**

Enter the selection to determine the timebase reference that will be used in measurements.

- **1 – 25-Hz External.** Uses an external reference. Requires that an external timebase of the indicated frequency be connected to the TDMA REF IN connector on the Test Set. When a valid external signal is detected, the REFERENCE Unlock indicator on the front panel of the Test Set will be extinguished and the Ext TDMA indicator will be lighted.
- **2 – 50-Hz External.** Same as for 25 Hz, except 50 Hz.
- **3 – 24.3-kHz External.** Same as for 25 Hz, except 24.3 kHz.
- **4 – 48.6-kHz External.** Same as for 25 Hz, except 48.6 kHz.
- **5 – 10-MHz External.** Same as for 25 Hz, except 10 MHz.
- **6 – 10-MHz Internal.** Uses the 10-MHz timebase in the Test Set. This is the default setting. It will be used unless an external reference signal of the correct frequency and amplitude is applied to the TDMA REF IN connector on the Test Set.

7. **LAP Baud Rate [valid test set range]**

Enter the value to determine the baud rate that will be used for communications between the PC and the SERIAL 9 port on the Test Set. Valid rates (bps) are: 150, 300, 600, 1200, 2400, 4800, 9600, 19200, 38400, and 57600. This setting must match the setting used by the PC communication software.

8. LAP Data Length [7 or 8]

Enter the selection to determine whether 7 or 8 bits will be used for the data length for the serial communication data link between the PC and the SERIAL 9 port on the Test Set. This setting must match the setting used by the PC communication software.

9. LAP Flow Control [1=None 2=Xon 3=Hw]

Enter the selection to determine the type of data flow control that will be used for the serial communication data link between the laptop PC and the SERIAL 9 port on the Test Set. This setting must match the setting used by the PC communication software.

- If you select 1, the link will use no flow control.
- If you select 2, the link will use Xon/Xoff flow control.
- If you select 3, the link will use hardware flow control. This setting must be used for baud rates of 38400 and higher.

10. LAP Parity [0=0 1=1 2=none 3=even 4=odd]

Enter the selection to determine the parity style that will be used for communication between the PC and the SERIAL 9 port on the Test Set.

- If you select 0, a zero parity will be used.
- If you select 1, a ones parity will be used.
- If you select 2, no parity will be used.
- If you select 3, an even parity will be used.
- If you select 4, an odd parity will be used.

11. LAP Stop Length [1 or 2]

Enter the selection to match the PC communication program settings that will be used for the number of stop bits in communications between the PC and the SERIAL 9 port on the Test Set.

- If you select 1, one stop bit will be used.
- If you select to 2, two stop bits will be used.

12. Not Used

13. Not Used

14. Not Used

15. Not Used

16. Not Used

17. **MSC BTS Type [1=Series II 2=M 3=MM 4=PCS]**

Enter the selection to specify the type of Base Station to be tested.

- Select 1 to indicate to the Test Software that the Base Station to be tested is of the Series II type.
- Select 2 to indicate to the Test Software that the Base Station to be tested is of the Series M type.
- Select 3 to indicate to the Test Software that the Base Station to be tested is of the Series MM type.
- Select 4 to indicate to the Test Software that the Base Station to be tested is of the PCS Minicell type.

18. **MSC Cell Site Number [444 Max]**

Enter the number of the cell site at which testing is to be performed.

19. **MSC ECP Number**

Enter the number of the ECP that controls the cell site at which testing is to be performed.

20. **MSC Require CP INH at Ant Port [1=Yes]**

Enter the selection to determine whether the entire cell site or the specific sector is to be taken out of service.

- If you select 1, all call processing will be inhibited, which takes the entire cell site out of service for testing at the Base Station TX Antenna Ports.
- If you select 0, only the sector that is associated with the specific antenna port at which testing is to be performed will be taken out of service.

NOTE

When testing at the Base Station TX Antenna Port, always verify that no radios are transmitting on the antenna at which testing is to be performed before disconnecting the antenna.

21. **TDMA DCCH Equipped [0=No 1=Yes]**

- Select 0 to indicate to the Test Software that the Base Station to be tested does not use a Digital Control Channel (DCCH).
- Select 1 to indicate to the Test Software that the Base Station to be tested does use a DCCH.

NOTE

This parameter must be set to 1 to allow specification of the DCCH ID number for the antenna associated with the TDMA Digital Control Channel. See [“Single Radio Test” on page 70](#).

22. **TDMA Number of Averages for Readings**

Enter the value to determine the number of measurement samples that will be used in calculating the average value of TDMA measurements. (Averaging is helpful when measurements fluctuate during a short period and cause an intermittent test point failure.).

23. TX Antenna Port Cable Loss

Enter the value of the cable loss in testing from the Base Station TX Antenna Port. If you do not know this value, use the TX Antenna Port Cable Calibration function of the Test Software to measure it. See [“TX Antenna Port Cable Calibration” on page 87](#).

24. TX Coupling Factor [ANT 0]

Enter the value of coupling factor for the Base Station TX Test Port for the specified antenna.

25. TX Coupling Factor [ANT 1]

Enter the value of coupling factor for the Base Station TX Test Port for the specified antenna.

26. TX Coupling Factor [ANT 2]

Enter the value of coupling factor for the Base Station TX Test Port for the specified antenna.

27. TX Coupling Factor [ANT 3]

Enter the value of coupling factor for the Base Station TX Test Port for the specified antenna.

28. TX Coupling Factor [ANT 4]

Enter the value of coupling factor for the Base Station TX Test Port for the specified antenna.

29. TX Coupling Factor [ANT 5]

Enter the value of coupling factor for the Base Station TX Test Port for the specified antenna.

30. TX Coupling Factor [ANT 6]

Enter the value of coupling factor for the Base Station TX Test Port for the specified antenna.

31. TX Output Power

Enter the value of the power level (in watts) that should be transmitting at the Base Station TX Antenna Port/foam jumper.

32. TX Test Port Cable Loss

Enter the value of the cable loss to be used in testing from the Base Station TX Test Port. If you do not know this value, use the TX Antenna Port Cable Calibration function of the Test Software to measure it. See [“TX Test Port Cable Calibration” on page 89](#).

33. TX Use 230 kHz BW on Data Dev [1=yes]

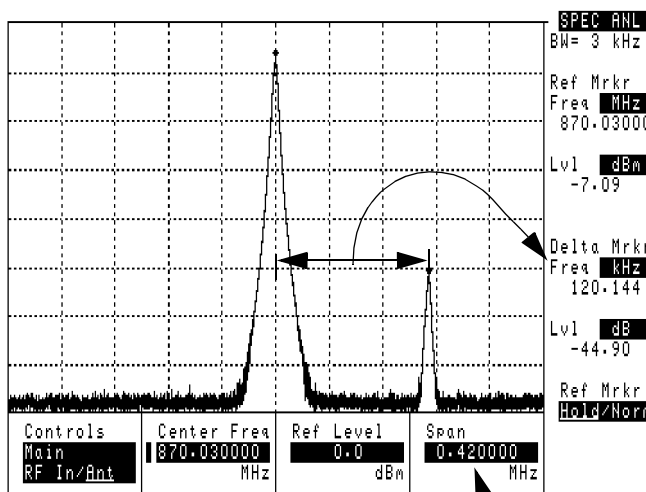
Enter the selection to determine which of the filters in the Test Set will be used in data deviation measurements in either the Single Radio Test or Full Site Test.

- If you select 1, the 230-kHz filter will be used. This is the default selection.
- If you select 0, the 30-kHz filter will be used.

When using the 230-kHz IF filter, the Base Station must not be transmitting another signal within seven channel spacings (210 kHz) above or below the signal being measured; otherwise the measurement will be in error. In [Figure 5-18](#), the Spectrum Analyzer and delta marker functions are used to illustrate that another signal could interfere with the measurement. (See the *Reference Guide* for information on using the Spectrum Analyzer).

It is preferable to use the 230-kHz filter when possible. However, if it is not possible to turn off a transmitter that is within 210 kHz of the signal to be measured, use the narrow (30-kHz) filter.

Figure 5-18 Determining the Best IF Filter Setting



Using the Delta Markers function, you can see that a smaller signal is only 120 kHz (four channel spacings) away from the signal you want to measure. In this case, set [Parameter 33 - TX Use 230 kHz BW on Data Dev \[1=yes\]](#) to **0** to reduce the measurement bandwidth, or turn off the other radio.

By setting the Spectrum Analyzer Span to 0.420 MHz, you can see if any interfering signals exist on either side of the measured signal.

34. ZZZZ Test Demo Mode [0=normal 1=demo]

Enter the selection to determine whether the Test Software will operate in normal or demonstration mode.

- If you select 0, the Test Software will run in normal mode, which allows for test measurements.
- If you select 1, the Test Software will run in demonstration mode. This mode appears to run tests, but the tests are simulated because there is no connection to a Base Station. This mode allows you to become familiar with Test Software operation. For details, see [“Demo \(Demonstration\) Mode” on page 120](#).

Specifications (Pass/Fail Limits)

The Test Software uses the entries in the TESTS (Pass/Fail Limits) screen to determine if a measurement meets the test requirements. If not, it displays a “fail” indication in the results display (and, in some instances, provides for adjustments and re-test).

This section lists the specification limit names and explains how each is used. For instructions on changing the pass/fail limits and saving the changes to an SRAM card, see [“Changing Pass/Fail Limits” on page 110](#) and [“Saving/Deleting a Procedure” on page 113](#).

1. AMPS Data Peak Deviation

Enter the upper and lower deviation limits, in kHz.

The 1004-Hz test signal in the Base Station is sent to the data modulator in the radio and the Test Software measures the resulting peak deviation and compares the result with the limits.

2. AMPS Deviation at -16 dBm Audio Level

Enter the upper and lower deviation limits, in kHz.

The 1004-Hz test signal in the Base Station is set to a level of -16 dBm, and is then sent to the analog modulator in the radio. The Test Software measures the resulting deviation and compares the result with the limits.

3. AMPS Deviation at 0 dBm Audio Level

Enter the upper deviation limit only, in kHz.

The 1004-Hz test signal in the Base Station is set to a level of 0 dBm, and is then sent to the analog modulator in the radio. The Test Software measures the resulting deviation and compares the result with the limit.

4. AMPS Distortion at -16 dBm Audio Level

Enter the upper distortion limit only, in percent (%).

The 1004-Hz test signal in the Base Station is set to a level of -16 dBm, and is then sent to the analog modulator in the radio. The Test Software measures the resulting distortion is compares the result with the limit.

5. AMPS Frequency Error

Enter the upper and lower limits, in Hz.

The Test Software measures the transmitter center frequency and compares it with the ideal frequency, based on the entry for channel number. The difference between the two is the frequency error. The Test Software then compares the calculated frequency error is then compared with the limits.

6. AMPS Residual FM [15 Hz - 15 kHz]

Enter the upper and lower limits, in Hz.

With all modulation turned off, the Test Software measures the amount of FM present in the rf carrier from the radio.

7. AMPS SAT Frequency Error

Enter the upper and lower limits, in Hz.

The Test Software measures the difference between the measured SAT frequency and the SAT frequency specified in the Base Station Configuration Menu, and compares the result with the limits.

When testing all SAT frequencies, the Test Software changes the SAT frequency to measure each frequency in sequence, using the same frequency error limits for all measurements.

8. AMPS SAT Peak Deviation

Enter the upper and lower limits, in Hz.

The Test Software measures the peak deviation for the SAT with all other modulation turned off, and compares the result with the limits.

9. Output Power Adjustment Error

Enter the upper and lower limits, in dB.

These limits determine how the power meter will be displayed. When the power meter display is displayed, it includes major tick marks that indicate the adjustment range for power settings. If you enter ± 1 dB as the limits, the meter will be drawn with the ideal setting in the center and major tick marks 1-dB up and 1-dB down from center.

10. Output Power Error

Enter the upper and lower limits, in dB.

While the previous limits (**Output Power Adjustment Error**) controlled the adjustment diagram in power meter use, the **Output Power Error** limits determine whether the power measurement made in automated testing meets specifications. If you set **Output Power Error** limits of ± 2 dB, these limits will be used when a power measurement is made. If the power measured is more than 2 dB from the desired setting, a fail indication (**F**) will result.

NOTE

In general, it is best to set the **Output Power Adjustment Error** limits set narrower (smaller) than the **Output Power Error** limits.

11. TDMA Adjacent Channel Power

Enter the upper limit only, in dB, relative to the level of the signal on the intended transmitter channel.

The Test Software measures the power inadvertently transmitted one channel spacing above and one channel spacing below the intended transmitted channel, and compares the result with the limit, which is the maximum.

For example, if the transmitter is supposed to be transmitting at 850.030 MHz, and the channels are 30 kHz apart, the Test Software measures the levels at 850 MHz and 850.060 MHz and compares the result with the level of the intended channel.

12. TDMA Error Vector Magnitude

Enter the upper limit only, in percent.

The Test Software measures the error vector magnitude and compares the result with the limit, which is the maximum. This measurement typically indicates the quality, or balance, of the IQ modulator in the transmitter.

13. TDMA First Alternate Channel Power

Enter the upper limit only, in dB, relative to the level of level of the signal on the intended transmitter channel. See [Specification 11 - TDMA Adjacent Channel Power](#).

The Test Software measures the power inadvertently transmitted two channel spacings above and two channel spacings below the intended transmitted channel, and compares the result with the limit, which is the maximum.

14. TDMA Frequency Error

Enter the upper and lower limits, in Hz.

The Test Software measures the transmitter center frequency and compares it with the ideal TDMA channel frequency, based on the entry for channel number. The difference between the two is the frequency error. The calculated frequency error is then compared to these pass/fail limits to determine if the test passes or fails.

15. TDMA Origin Offset

Enter the upper limit only, in dB.

The Test Software calculates the difference between the measured IQ modulation origin point and an ideal reference origin. Excessive origin offset might indicate an unbalanced IQ modulator in the transmitter.

16. TDMA Second Alternate Absolute Power

Enter the upper limit only, in dBm.

The Test Software measures the power three channel spacings above and three channel spacings below the intended transmitted channel, and compares the result with the limit, which is the maximum. Unlike the adjacent channel power measurements in which the power is measured relative to the transmitted power (in dB), this measurement measures the *absolute* power (in dBm) at frequencies 90 kHz above and below the transmitted signal.

17. TDMA Second Alternate Channel Power

Enter the upper limit only, entered in dB, relative the to level of the intended transmitted channel signal. See [Specification 11 - TDMA Adjacent Channel Power](#).

The Test Software measures the power inadvertently transmitted three channel spacings (90 kHz) above and three channel spacings below the intended transmitted channel, and compares the result with the limit, which is the maximum.

Testing without MSC Control

Chapter 4, “Performing Tests,” on page 61 lists the steps for fully automated testing, using the Test Software to control the Base Station. The steps of that chapter use a PC to control the Base Station via the MSC.

If you are using a Test Set setup with no PC and connection to the MSC, the following considerations apply:

- Make certain to set the **Send Control Commands to MSC** field on the Base Station Configuration Menu to **NO**. The Test Set will not send control commands to the MSC using the PC.
- The connection diagrams at the start of each test sequence will include prompts to apply or remove power for the BBA being tested. You must control the transmitter signal (on and off) manually at the site.
- You will probably require an assistant at the MSC to control the Base Station and remove the radios from service.

Using a PC Card

Before a PC card may be used for the first time, it must be initialized. The following two sections describe the initialization process and offer some troubleshooting information in the event of a problem with the use of a PC card.

Initializing a PC Card

When a card is new, or the battery has been removed when the card is not inserted into the Test Set, then the card must be initialized to store data. To initialize a PC card follow these steps:

- Step 1.** Insert the PC card into the front-panel card slot
- Step 2.** If a Test Software package is running, press the **Shift** key, then the **Pause/Continue** key to stop it.
- Step 3.** Press the **Shift** key, then the **Inst Config** key. The Test Set will display the I/O CONFIGURE screen.
- Step 4.** Select the **Format Card** field. The Test Set will display a query asking if you wish to “Erase and format the PCMCIA Card?” (YES/NO).
- Step 5.** Press the **Yes On/Off** key, located below and to the right of the knob, to format the card.
The card is formatted when the cursor stops blinking.

Troubleshooting PC Card Use

Each of the messages listed below is followed by an explanation of the probable cause.

Directory Overflow.

- The SRAM card is probably full and cannot store new files. You might have to delete some files on the card to clear memory space or use a new PC card.

Medium uninitialized. Do you want to initialize?

- The card either not been initialized or has other information stored on it. Initializing overwrites any data that might already be on the card. Press the **Yes On/Off** key to initialize the installed card.

Write protected.

- The card has been write protected (the switch in the WP position). Slide the write protect switch into the other position before writing.

Medium changed or not in drive. No information was loaded.

- The card has possibly not been inserted properly. Re-insert and try again.

File name is undefined. No information was loaded.

- There might be no information (files) stored on the card.
- You might not have inserted the correct card in the PC card slot. Try again with a different card.

6 Troubleshooting

This chapter contains information that is useful if you encounter Test Software or measurement errors or if you question measurement results.

Error Summary

Overview

This chapter lists errors that might be encountered when loading or running the Test Software. The errors are listed roughly in the order of possible occurrence when getting started using the Test Software:

[“Troubleshooting the Test Software Installation” on page 137.](#)

[“Errors When Loading and Running the Test Software” on page 138.](#)

[“Errors When First Setting Up or Connecting to MSC” on page 139.](#)

[“Communication Errors During Testing” on page 139.](#)

[“Errors While Attempting Measurements” on page 141.](#)

Help for Communication Errors:

The following sections include checks and tools that may be used to troubleshoot communication errors between the Test System and the MSC:

[“Troubleshooting Checks for Communication Problems” on page 140.](#)

Troubleshooting the Test Software Installation

If the Test Software did not install properly, check the following:

- Is the power on?
- Is the PC card inserted in the correct orientation?
- Is the PC card firmly seated in the slot? It should slide in loosely, then be firmly pushed in to make proper contact.
- Did the SOFTWARE MENU screen appear? Pressing the front panel **Preset** key should display the SOFTWARE MENU screen.
- Did TESTS (IBASIC Controller) appear at the top of the display after you pressed the **k1 (Run Test)** key? If not, make certain that you have specified the correct **Procedure Location** and **Procedure Filename**.

If you were unable to load and run the Test Software, make the required entries, or you encountered error messages, refer to other sections of this chapter.

NOTE

If the Test Set displays an error that states “One or more self-tests failed”, there is a hardware problem. In this case, refer to the *Test Set Assembly Level Repair Guide*. If the problem persists, call the Agilent Technologies Factory Hotline from anywhere in the USA or Canada (1-800-452-4844), 8:30 am - 5:00 pm Pacific time).

Errors When Loading and Running the Test Software

This group of errors would most often be encountered before the Main Menu appears. Such errors would be most likely to occur the first time that you load and run the Test Software (see [Chapter 2, “Installation,” on page 21](#)). The errors are presented with the error text, followed by a description of the cause, followed by some possible solutions.

- **Symptom: Memory Overflow Errors**

The random access memory (RAM) space of the Test Set is shared by IBASIC programs and save/recall registers. If you have saved a large number of registers in the Test Set, a memory overflow error might occur when you first attempt to load the Test Software.

To correct this, clear some RAM space by deleting some or all of the saved registers. You may do this selectively (one register at a time) or globally (all storage registers at once).

NOTE

Clearing registers, whether selectively or globally, is *permanent*. *Registers are not retrievable once deleted*. You may save registers to an SRAM card. Refer to the *Agilent Technologies 8935 Reference Guide* for instructions on this procedure.

To delete a single saved register:

- Step 1.** Press the **Recall** key.
- Step 2.** Scroll the cursor to the register to be deleted.
- Step 3.** Press the **Yes On/Off** key to indicate that you wish to clear the register.
- Step 4.** Press the **Yes On/Off** key again to confirm.
- Step 5.** The register will be cleared.

To delete all saved registers:

- Step 1.** Press the **Recall** key.
- Step 2.** Scroll to ***Clr All*** and press the knob.
- Step 3.** Press the **Yes On/Off** key to confirm.
- Step 4.** All save registers will be cleared.

Communication Errors

Errors When First Setting Up or Connecting to MSC

- Message: Base Station did not answer..

If commands are misunderstood at the MSC end, this error message might occur. Use the **Switch Terminal** window in the BTS Laptop Utility program to send commands and view responses to identify the problem command. Also, refer to [“Troubleshooting Checks for Communication Problems” on page 140](#) for a list of items to check when you have noticed this error.

Communication Errors During Testing

Message: Lost the modem carrier. Use the BTS Laptop Utility program to correct the problem and to return all configured BBAs back to active status. Press the **Abort** key to return to the main menu.

This error indicates that communication with the MSC was taking place, but the link was lost sometime during the testing process.

As indicated in the message, you may use the BTS Laptop Utility program to try to re-establish the link with the MSC.

Also check the items in [“Troubleshooting Checks for Communication Problems” on page 140](#) for possible causes of interruptions to the communication between the Test System and the MSC.

Troubleshooting Checks for Communication Problems

The following list provides items to check when you are having communication difficulties using the external modem to connect to the MSC.

- Cable connections:

Make certain that you have made the proper connections between the Test Set serial port, the phone line or telnet connection, and the personal computer (PC).

A list of cables and part numbers is provided in [“Optional Accessory Kits” on page 17](#).

- Dialing difficulties:

In some cases, you might have to customize the dialing information in order to properly dial and connect to the MSC. For example, if there is a 9 in the dialing sequence to obtain an outside phone line, there might be a short delay before the dial tone is heard. Therefore, a delay after the 9 might be required before the rest of the digits in the sequence are sent. This may be done from the Switch Terminal window of the BTS Laptop Utility program. Clicking on the Dial button on the Switch Terminal window tool bar, and add a comma between the numbers as shown in the following example.

9, 1-509-835-0000

- MSC is not configured to send responses to commands:

After sending a control command to the MSC, the Test Software searches for response commands from the MSC before continuing. It might be that the MSC with which the system is communicating has been configured to not send responses to remote computers. You might have to check with a switch technician to determine if this is the case for the MSC in question.

Errors While Attempting Measurements

The following error messages might be posted once a test mode has begun making measurements:

- Full Site Test (FCC) is selected but does not run.

The Full Site Test uses a frequency plan to provide the required cell site and radio information. If the Test Software cannot locate a frequency plan, it exits the test. See [“Defining a Frequency Plan” on page 45](#) for information on the contents and creation of frequency plans.

- The indicated TX Power level is very low or very high.

Assuming that the radio is transmitting at the proper level, this problem is usually caused by incorrect parameter entries dealing with test cable and test port losses.

If testing at the Base Station TX Test Port:

- Verify that the **Base Station Connection** field on the Base Station Configuration Menu is set to **TX Test Port**.
- Verify that the Base Station TX Test Port is connected to the Test Set ANT IN port (as shown in the setup drawing that appears at the start of the test).
- Measure the coupling factor for the Base Station TX Test Port and make certain that the value is entered in the Base Station Configuration menu. See [“TX Test Port Coupling Measurements” on page 91](#).
- Measure the Base Station TX Test Port Cable Loss and enter it on the Base Station Configuration Menu. See [“TX Test Port Cable Calibration” on page 89](#).
- Verify that you have entered the correct VRAL/CSAC setting for the selected radio at the start of the test.

If testing at the Base Station TX Antenna Port (foam jumper):

- Verify that the Base Station TX Antenna Port is connected to the Test Set RF IN/OUT port (as shown in the setup drawing that appears at the start of the test).
- Verify that the **Base Station Connection** field on the Base Station Configuration Menu is set to **TX Antenna Port**.
- Measure the Base Station TX Antenna Port Cable Loss and enter it on the Base Station Configuration Menu. See [“TX Antenna Port Cable Calibration” on page 87](#).
- Verify that you have entered the correct VRAL/CSAC setting for the selected radio at the start of the test.

Troubleshooting Frequency Plans

The following error messages might be posted once a test has been selected:

- Message: No DCCH radio found in plan for antenna x.

This message might be generated when running the Full Cell Site Test only (other tests do not use frequency plans). The message will appear if the frequency plan that you defined for the site does not include at least on DCCH radio per antenna.

To remedy this condition, either:

- Select the **Define Frequency Plan** field in the Calibration/Utilities Menu screen and correct the plan for the site number being tested (see [“Defining a Frequency Plan” on page 45](#)).

or

- Set Parameter 21 [“TDMA DCCH Equipped \[0=No 1=Yes\]” on page 126](#) to No.

- Message: Multiple DCCH radios found in plan for antenna x.

This message might be generated when running the Full Cell Site Test only (other tests do not use frequency plans). The message will appear if two or more digital control channels are defined for a single antenna.

To remedy this condition, either:

- Select the **Define Frequency Plan** field in the Calibration/Utilities Menu screen and correct the plan for the site number being tested (see [“Defining a Frequency Plan” on page 45](#)).

or

- Set Parameter 21 [“TDMA DCCH Equipped \[0=No 1=Yes\]” on page 126](#) to No.

A **Acronyms**

There are numerous acronyms used throughout the wireless communications field. Many of those are used in this manual. The following list provides the meanings for the more significant acronyms for purposes of operating the Test Software.

Acronyms and Meanings

ACU – Analog Conversion Unit
AIF – Antenna Interface Frame
AWGN – Added White Gaussian Noise
BBA – BIU/BCR/ACU combination
BCR – Baseband Combiner and Radio
BIU – Bus Interface Unit
CAT – Catalog
CCC – CDMA Cluster Controller
CCU – CDMA Channel Unit
CDMA – Code Division Multiple Access
CE – Channel Element
CP – Call Processing
CS – Cell Site
CR – Carriage Return
CRT – Cathode Ray Tube
CRTU – CDMA Radio Test Unit
dB – deciBel
dBm – deciBels with respect to 1 milliwatt
dBt – deciBels with respect to total channel power
DTMF – Dual Tone Multi Frequency
DUT – Device Under Test
Eb/No – Ratio of Energy-per-Bit to Noise spectral density
ECP – Executive Cellular Processor
ERP – Effective Radiated Power
EVM – Error Vector Magnitude
GPS – Global Positioning System
LAP – Laptop PC
LED – Light Emitting Diode
MHz – Megahertz
MSC – Mobile Switching Center (also, MTSO)
OMP – Operations Management Platform
OOS – Out-Of-Service
OP – Output Process

OTP – One-Time Programmable
PC – Personal Computer
PCS – Personal Communications Services
PN – Pseudo-Noise
RAM – Random-Access Memory
RF – Radio Frequency
RX – Receiver
SCT – Synchronized Clock and Tone
TX – Transmitter
VSWR – Voltage Standing Wave Ratio
UCL – UnConditional

Numerics

- parameter
 - INST TDMA Ref, 124
 - INST Synth Ref, 124

A

- Accessing Test Software
 - Functions, 101
 - Changing Pass/Fail Limits, 110
 - Changing Test Parameters, 107
 - Customizing a Test Procedure, 106
 - Loading a Test Procedure, 103
 - Loading the Test Software Card and Procedure, 104
 - Saving/Deleting a Procedure, 113
 - SOFTWARE MENU Screen
 - Overview, 102
- accessory kit, 17
- acronyms list, 144
- adapters, description, 17
- AMPS Data Peak Deviation
 - specification, 129
- AMPS Deviation at 0 dBm Audio
 - specification, 129
- AMPS Deviation at -16 dBm
 - Audio specification, 129
- AMPS Distortion at -16 dBm
 - Audio specification, 129
- AMPS frequency error
 - specification, 129
- AMPS Residual FM specification, 129
- AMPS SAT Frequency Error
 - specification, 130
- AMPS SAT Peak Deviation
 - specification, 130
- ANT IN port, 36
- Antenna Port connections, 36

B

- Base Station Configuration menu, 41
- base station control errors, 139
- BTS Laptop Utility program, 15
 - installing, 28
 - operation, 27
 - Other Data Window, 117
 - Switch Terminal Window, 117
 - Test Results Window, 118
 - Test Set Screen Capture window, 119
 - Test Set Terminal Window, 117
- BTS Laptop Utility program
 - system requirements, 28

- BTS Laptop Utility Program
 - Windows, 117

C

- cable loss measurement, 94
- cables and adapters required, 15
- Calibrate TX Test Port mode, 91
- changing settings, 26
- Choices, 9
- code domain
 - power measurement errors, 141
- communication errors, 139
 - troubleshooting checks, 140
- configuring the PC, 31
- configuring the PC serial port, 29
- configuring the Test Set SERIAL 9 port, 29
- configuring the Test Software, 38
- connection
 - modem, 31
 - MSC to PC, 32
 - telnet, 31
 - Test Set to PC, 32
- connections
 - clock or external reference, 36
 - hardware, 27
 - site equipment to Test Set, 36
 - Test or Antenna port, 36
 - Test Set port, 36
 - Test Set to site equipment, 36
- conventions used, 9

D

- defining a frequency plan using a PC, 48
- deleting
 - a frequency plan, 52
- demo (demonstration) mode, 120
- demo mode
 - selecting, 120
- DEMO procedure
 - selecting, 120
- description
 - parameters, 122
- direct-dial modem connection, 54

E

- ENTER key, 9
- equipment
 - required, 15
- error
 - base station control, 139
 - baud rates, 139
 - code domain power measurement, 141

- communication, 139
- loading and running, 138
- measurement, 141
- modem carrier, 139
- establishing connection with the MSC, 54

F

- FCC Title Page, printing, 43
- field
 - selecting a, 9
- frequency plan, 45
 - defining using a PC, 48
 - loading, 52
 - printing, 53
 - purging (deleting), 52
- frequency plans
 - troubleshooting, 142
- functions
 - Main Menu, 25

G

- GN MSC command Speed
 - parameter, 123

H

- Help, 20
- How to LOAD TEST PROCEDURES, 103

I

- insertion loss test mode, 94
- in-service testing, 36
- installing the BTS Laptop Utility program, 28
- instrument, 27
- instrument connections, 27

K

- kit, accessory
 - cables, description, 17

L

- list
 - acronyms, 144
 - parameters, 122
 - specifications (pass/fail limits), 129
- load, 23
- load Test Software, 23
- loading
 - a frequency plan, 52
- loss
 - return, 96

M

- Main Menu functions, 25
- measurement errors, 141
- measuring
 - insertion loss, 94
 - power, 74
 - spectrum, 77
- menu
 - Base Station Configuration, 41
 - Test Configuration, 39
- message, error, 138
- mode
 - Calibrate TX Test Port, 91
 - insertion loss test, 94
 - spectrum analyzer test, 77
 - TX power meter, 74
- modem
 - carrier error, 139
- modem connection, 31
- MSC, 27
- MSC connection, 54
- MSC connections, 27
- MSC control, testing without, 132

N

- navigating the Test Software, 25

O

- operating the BTS Laptop Utility Program
 - BTS Laptop Utility program operation, 27
- operation overview
 - software, 14
- out-of-service testing, 37
- output power adjustment error specification, 130
- output power error specification, 130

P

- parameter
 - Adjust TX Power, 122
 - GN Power Output, 123
 - GN Stop Test if results fail, 123
 - LAP Baud Rate, 124
 - LAP Data Length, 125
 - LAP Flow Control, 125
 - LAP Parity, 125
 - LAP Stop Length, 125
 - list, 122
 - MSC BTS Type, 126
 - MSC Cell Site Number, 126
 - MSC ECP Number, 126

- MSC Require CP INH at Ant Port, 126
- TDMA DCCH Equipped, 126
- TDMA Number of Averages, 126
- TX Antenna Port Cable Loss, 127
- TX Coupling Factor ANT 0, 127
- TX Coupling Factor ANT 1, 127
- TX Coupling Factor ANT 2, 127
- TX Coupling Factor ANT 3, 127
- TX Coupling Factor ANT 4, 127
- TX Coupling Factor ANT 5, 127
- TX Coupling Factor ANT 6, 127
- TX Output Power, 127
- TX Test Port Cable Loss, 127
- TX Use 230 kHz on Data Dev, 128
- ZZZZ Test Demo Mode, 128
- PC, 27
 - configuring, 31
 - PC (personal computer), 15
 - PC connections, 27
 - PC serial port
 - configuring, 29
 - PC to MSC connections, 32
 - PC to Test Set connections, 32
 - phone support, 20
 - plans, frequency, 45
 - power, 36
 - power measurements, 74
 - power meter, 74
 - printing
 - a frequency plan, 53
 - FCC Title Page, 43
 - purging (deleting)
 - a frequency plan, 52
- R
 - required equipment, 15
 - return loss
 - test description, 96
 - RF IN/OUT port power, 36
 - run Test Software, 23

S

- service, Test Set, 20
- setup, 27
- software
 - operation overview, 14
 - Software upgrades, 20
 - special display conventions used, 9
 - specification
 - AMPS Data Peak Deviation, 129
 - AMPS Deviation at 0 dBm Audio, 129

- AMPS Deviation at -16 dBm Audio, 129
- AMPS Distortion at -16 dBm Audio, 129
- AMPS Frequency Error, 130
- AMPS frequency error, 129
- AMPS Residual FM, 129
- AMPS SAT Peak Deviation, 130
- list, 129
- output power adjustment error, 130
- output power error, 130
- TDMA Adjacent Channel Power, 130
- TDMA Error Vector Magnitude, 131
- TDMA First Alternate Channel Power, 131
- TDMA Frequency Error, 131
- TDMA Origin Offset, 131
- TDMA Second Alternate Absolute Power, 131
- spectrum analyzer test mode, 77
- spectrum measurements, 77
- support, 20
- system requirements
 - BTS Laptop Utility program, 28

T

- TDMA Adjacent Channel Power specification, 130
- TDMA Error Vector Magnitude specification, 131
- TDMA First Alternate Channel Power specification, 131
- TDMA Frequency Error specification, 131
- TDMA Origin Offset specification, 131
- TDMA Second Alternate Absolute Power specification, 131
- telnet connection, 31, 54
- Test Configuration menu, 39
- test equipment required, 15
- Test Port connections, 36
- Test Set, 27
- Test Set connections, 27
- Test Set SERIAL 9 port
 - configuring, 29
- Test Set service, 20
- Test Set to PC connection, 32
- Test Set to site equipment connections, 36
- Test Software
 - navigation, 25
 - run, 23
 - Test Software configuration, 38

testing without MSC control, 132
training, 20
troubleshooting checks for
 communication errors, 140
troubleshooting frequency plans,
 142
TX Antenna Port for out-of-service
 testing, 37
TX power meter mode, 74
TX Test port coupling factor, 36
TX Test Port for in-service testing,
 36

U

upgrades,software, 20
USER keys, 9, 26